



Variable Wavelength Detectors
Agilent InfinityLab LC Series
User Manual



Notices

Document Information

Document No: SD-29000240 Rev. D

EDITION 09/2020

Copyright

© Agilent Technologies, Inc. 2014-2020

No part of this manual may be reproduced in any form or by any means (including electronic storage and retrieval or translation into a foreign language) without prior agreement and written consent from Agilent Technologies, Inc. as governed by United States and international copyright laws.

Agilent Technologies
Hewlett-Packard-Strasse 8
76337 Waldbronn

Warranty

The material contained in this document is provided "as is," and is subject to being changed, without notice, in future editions. Further, to the maximum extent permitted by applicable law, Agilent disclaims all warranties, either express or implied, with regard to this manual and any information contained herein, including but not limited to the implied warranties of merchantability and fitness for a particular purpose. Agilent shall not be liable for errors or for incidental or consequential damages in connection with the furnishing, use, or performance of this document or of any information contained herein. Should Agilent and the user have a separate written agreement with warranty terms covering the material in this document that conflict with these terms, the warranty terms in the separate agreement shall control.

Technology Licenses

The hardware and/or software described in this document are furnished under a license and may be used or copied only in accordance with the terms of such license.

Restricted Rights Legend

U.S. Government Restricted Rights. Software and technical data rights granted to the federal government include only those rights customarily provided to end user customers. Agilent provides this customary commercial license in Software and technical data pursuant to FAR 12.211 (Technical Data) and 12.212 (Computer Software) and, for the Department of Defense, DFARS 252.227-7015 (Technical Data - Commercial Items) and DFARS 227.7202-3 (Rights in Commercial Computer Software or Computer Software Documentation).

Safety Notices

CAUTION

A **CAUTION** notice denotes a hazard. It calls attention to an operating procedure, practice, or the like that, if not correctly performed or adhered to, could result in damage to the product or loss of important data. Do not proceed beyond a **CAUTION** notice until the indicated conditions are fully understood and met.

WARNING

A **WARNING** notice denotes a hazard. It calls attention to an operating procedure, practice, or the like that, if not correctly performed or adhered to, could result in personal injury or death. Do not proceed beyond a **WARNING** notice until the indicated conditions are fully understood and met.

In This Book

This manual covers:

- the Agilent 1290 Infinity II Variable Wavelength Detector (G7114B) and
- the Agilent 1260 Infinity II Variable Wavelength Detector (G7114A).

Find information on other Agilent Variable Wavelength Detectors in separate manuals.

1 Introduction to the Variable Wavelength Detector

This chapter gives an introduction to the detector, instrument overview and internal connectors.

2 Site Requirements and Specifications

This chapter gives information on environmental requirements, physical and performance specifications.

3 Using the Module

This chapter explains the essential operational parameters of the module.

4 Preparing the Module

This chapter provides information on how to set up the detector for an analysis and explains the basic settings.

5 Optimizing the Detector

This chapter provides information on how to optimize the detector.

6 Troubleshooting and Diagnostics

Overview about the troubleshooting and diagnostic features.

7 Error Information

This chapter describes the meaning of detector error messages, and provides information on probable causes and suggested actions how to recover from error conditions.

8 Test Functions

This chapter describes the detector's built in test functions.

9 Maintenance

This chapter provides general information on maintenance of the detector.

10 Parts and Materials for Maintenance

This chapter provides information on parts for maintenance.

11 Identifying Cables

This chapter provides information on cables used with the Agilent 1200 Infinity Series modules.

12 Hardware Information

This chapter describes the detector in more detail on hardware and electronics.

13 LAN Configuration

This chapter provides information on connecting the module to the Agilent ChemStation PC.

14 Appendix

This chapter provides addition information on safety, legal and web.

Contents

1	Introduction to the Variable Wavelength Detector	9
	Introduction to the Detector	10
	Product Description	11
	Optical System Overview	13
	Dual-Wavelength Mode	18
	Leak and Waste Handling	19
	Operating Principle	24
2	Site Requirements and Specifications	25
	Site Requirements	26
	Physical Specifications	29
	Performance Specifications	30
3	Using the Module	35
	Magnets	36
	Turn on/off	37
	Status Indicators	39
	Instrument Configuration	40
	Set up the Detector with Agilent Open Lab ChemStation	42
	The Detector User Interface	43
	Detector Control Settings	45
	Method Parameter Settings	46
	Scanning with the VWD	50
	Agilent Local Control Modules	52

4	Preparing the Module	53
	Leak and Waste Handling	54
	Setting up an Analysis	56
	Solvent Information	63
	Capillary Coding Guide	69
	Installing Capillaries	72
5	Optimizing the Detector	77
	Introduction	78
	Match the Flow Cell to the Column	79
	Set the Detector Parameters	82
	Warm up of the Detector	83
6	Troubleshooting and Diagnostics	85
	Available Tests versus Interfaces	86
	Agilent Lab Advisor Software	87
7	Error Information	88
	What Are Error Messages	89
	General Error Messages	90
	Detector Error Messages	97
8	Test Functions	107
	Introduction	108
	Intensity Test	113
	Cell Test	116
	Wavelength Verification-Calibration	118
	ASTM Drift and Noise Test	120
	Quick Noise Test	121
	Dark Current Test	123
	Holmium Oxide Test	125
	D/A Converter (DAC) Test	128
	Other Lab Advisor Functions	131

9	Maintenance	132
	Introduction to Maintenance	133
	Warnings and Cautions	134
	Overview of Maintenance	136
	Cleaning the Module	137
	Remove and Install the Doors	138
	Replace the Deuterium Lamp	140
	Replace the Flow Cell / Cuvette Holder	143
	Repair the Flow Cells	145
	Using the Cuvette Holder	149
	Correcting Leaks	151
	Replace Leak Handling System Parts	153
	Replace the Module Firmware	154
10	Parts and Materials for Maintenance	155
	Overview of Maintenance Parts	156
	Standard Flow Cell 10 mm / 14 μ l	158
	Micro Flow Cell 3 mm / 2 μ L	160
	Semi-micro Flow Cell (Parts)	162
	High Pressure Flow Cell (Parts)	164
	Bio Standard Flow Cell	166
	Bio Micro Flow Cell	168
	Cuvette Holder (Parts)	170
	Accessory Kit	171
11	Identifying Cables	172
	Cable Overview	173
	Analog Cables	175
	Remote Cables	177
	CAN Cable	181
	RS-232 Cables	182
	USB Cables	183

12	Hardware Information	184
	Firmware Description	185
	Electrical Connections	188
	Interfaces	191
	Setting the 6-bit Configuration Switch	199
	Instrument Layout	203
	Early Maintenance Feedback (EMF)	204
13	LAN Configuration	206
	What You Have to Do First	207
	TCP/IP parameter configuration	208
	Configuration Switch	209
	Initialization Mode Selection	210
	Dynamic Host Configuration Protocol (DHCP)	212
	Manual Configuration	215
14	Appendix	219
	General Safety Information	220
	Waste Electrical and Electronic Equipment (WEEE) Directive	229
	Radio Interference	230
	Sound Emission	231
	Solvent Information	232
	Declaration of Conformity for HOX2 Filter	233
	Agilent Technologies on Internet	234

1

Introduction to the Variable Wavelength Detector

Introduction to the Detector	10
Product Description	11
Product Description G7114A	11
Product Description G7114B	12
Optical System Overview	13
Flow Cell	14
Lamp	15
Source Lens Assembly	15
Entrance Slit Assembly	15
Filter Assembly	16
Mirror Assemblies M1 and M2	17
Grating Assembly	17
Beam Splitter Assembly	17
Photo Diodes Assemblies	17
Photo Diode ADC (analog-to-digital converter)	17
Dual-Wavelength Mode	18
Leak and Waste Handling	19
Leak Sensor	23
Waste Concept	23
Operating Principle	24

This chapter gives an introduction to the detector, instrument overview and internal connectors.

Introduction to the Detector

The Agilent variable wavelength detectors described in this manual are designed for highest optical performance, GLP compliance and easy maintenance with:

- higher data rate up to 120 Hz (G7114A) or 240 Hz for ultra-fast-HPLC (G7114B),
- deuterium lamp for highest intensity and lowest detection limit over a wavelength range of 190 to 600 nm,
- optional flow-cell cartridges (standard 10 mm, 14 μ L; high pressure 10 mm, 14 μ L; micro 3 mm, 2 μ L; semi-micro 6 mm, 5 μ L), Bio, and Prep Cells are available and can be used depending on the application needs (other types may be introduced later),
- Dual wavelength mode, see “Dual-Wavelength Mode” on page 18.
- easy front access to lamp and flow cell for fast replacement,
- electronic identification of flow cell and lamp with RFID (Radio Frequency Identification) tag for unambiguous identification,
 - lamp information: part number, serial number, production date, ignitions, burn time
 - cell information: part number, serial number, production date, nominal path length, volume, maximum pressure
- built-in electronic temperature control (ETC) for improved baseline stability, and
- built-in holmium oxide filter for fast wavelength accuracy verification.

Product Description

Product Description G7114A

The Agilent 1260 Infinity II Variable Wavelength Detector (VWD) is the most sensitive and fastest detector in its class.

Time-programmable wavelength switching provides sensitivity and selectivity for your applications.

More sample information can be acquired in the dual wavelength mode.

Low detector noise ($< \pm 1.5 \mu\text{AU}$) and baseline drift ($< 1 \times 10^{-4} \text{ AU/h}$) facilitates precise quantification of trace levels components.

High productivity can be achieved with fast analysis at up to 120 Hz data rates.

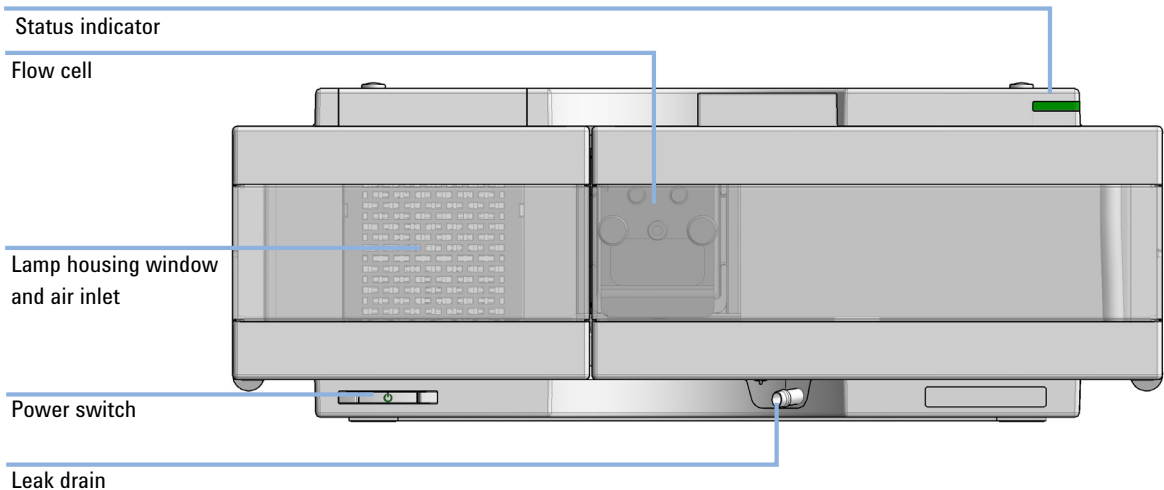

Figure 1 Overview of the detector

Product Description G7114B

The Agilent 1290 Infinity II Variable Wavelength Detector (VWD) is the most sensitive and fastest detector in its class.

Time-programmable wavelength switching provides sensitivity and selectivity for your applications.

More sample information can be acquired in the dual wavelength mode.

Low detector noise ($< \pm 1.5 \mu\text{AU}$) and baseline drift ($< 1 \cdot 10^{-4} \text{ AU/h}$) facilitates precise quantification of trace levels components.

High productivity can be achieved with fast analysis at up to 240 Hz data rates.

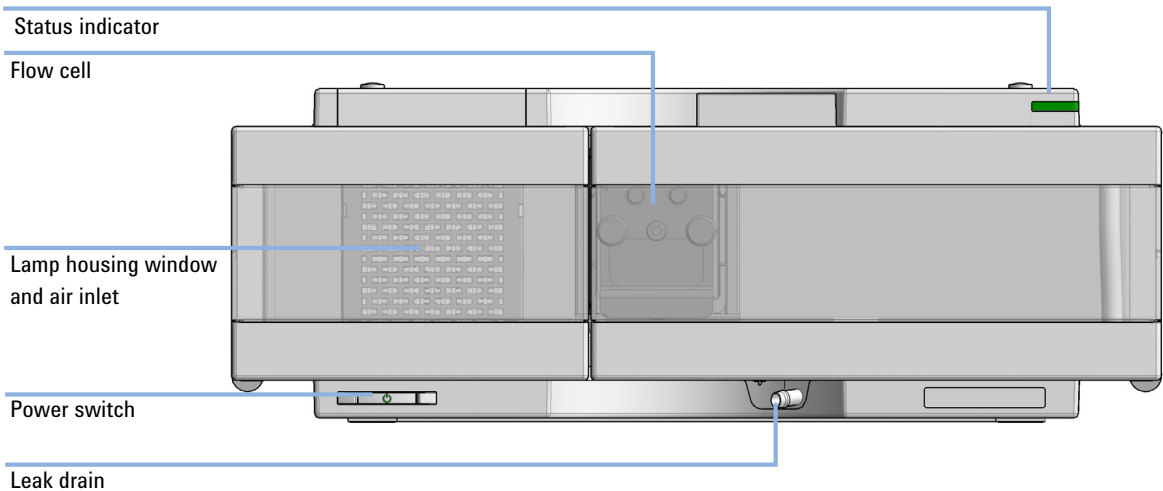

Figure 2 Overview of the detector

Optical System Overview

The optical system of the detector is shown in the figure below. Its radiation source is a deuterium-arc discharge lamp for the ultraviolet (UV) wavelength range from 190 to 600 nm. The light beam from the deuterium lamp passes through a lens, a filter assembly, an entrance slit, a spherical mirror (M1), a grating, a second spherical mirror (M2), a beam splitter, and finally through a flow cell to the sample diode. The beam through the flow cell is absorbed depending on the solutions in the cell, in which UV absorption takes place, and the intensity is converted to an electrical signal by means of the sample photodiode. Part of the light is directed to the reference photodiode by the beam splitter to obtain a reference signal for compensation of intensity fluctuation of the light source. A slit in front of the reference photodiode cuts out light of the sample bandwidth. Wavelength selection is made by rotating the grating, which is driven directly by a stepper motor. This configuration allows fast change of the wavelength. The cutoff filter is moved into the lightpath above 370 nm to reduce higher order light.

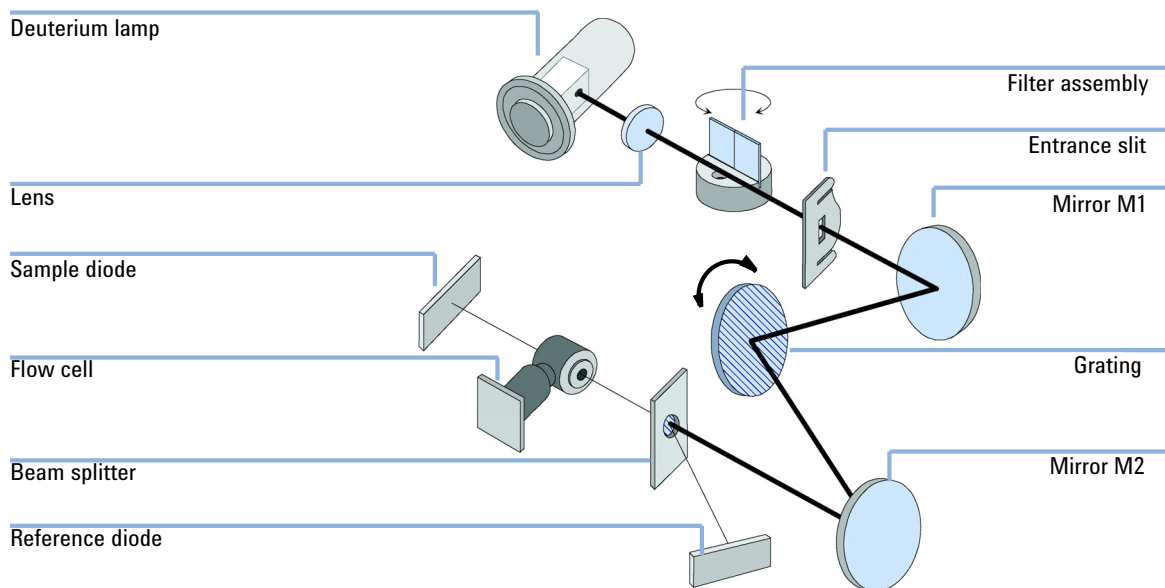

Figure 3 Optical Path of the Variable Wavelength Detector

Flow Cell

A variety of flow-cell cartridges can be inserted using the same quick and simple mounting system.

The flow cells have an integrated RFID tag that contains the flow cell specific information (e.g. part number, cell volume, path length, ...). A RFID tag reader reads out this information and transfers it to the user interface.

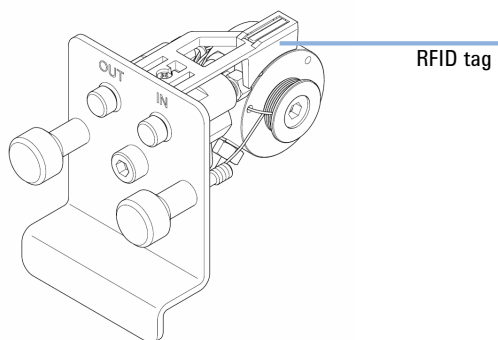

Figure 4 Flow Cell with RFID tag

Table 1 Flow cell data

	Standard	Semi-micro	Micro	High Pressure	Bio Standard	Bio Micro
Maximum pressure (bar (MPa))	40 (4)	40 (4)	120 (12)	400 (40)		
Path length (mm)	10 (conical)	6 (conical)	3 (conical)	10 (conical)	10 (conical)	3 (conical)
Volume (µL)	14	5	2	14	14	2
Inlet i.d. (mm)	0.25	0.17	0.12	0.25	14	0.12
Inlet length (mm)	750	250	310	750	750	310
Outlet i.d. (mm)	0.30	0.17	0.17	0.17	0.30	310
Outlet length (mm)	120	120	120	120	120	310
Total volume (µL)	60.77	14.49	14.00	60.77	60.77	310
Materials in contact with solvent	SST, quartz, PTFE, PEEK	SST, quartz, PTFE	SST, quartz, PTFE	SST, quartz, Kapton	MP35N, sapphire	MP35N, sapphire

Lamp

The light source for the UV wavelength range is a deuterium lamp. As a result of plasma discharge in a low pressure deuterium gas, the lamp emits light over the 190 – 600 nm wavelength range.

The lamp has an integrated RFID tag that contains the lamp specific information (e.g. part number, burn time, ...). An RFID tag reader reads out this information and transfers it to the user interface.

Source Lens Assembly

The source lens receives the light from the deuterium lamp and focuses it onto the entrance slit.

Entrance Slit Assembly

The entrance slit assembly has an exchangeable slit. The standard one has a 1-mm slit. For replacement and calibration purposes to optimize the alignment, a slit with a hole is needed.

Filter Assembly

The filter assembly is electromechanically actuated. During wavelength calibrations it moves into the light path.

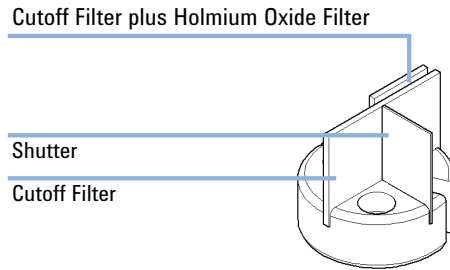

Figure 5 Filter Assembly

The filter assembly has two filters installed and is processor-controlled.

OPEN	nothing in light path at $\lambda < 370$ nm
CUTOFF	cut off filter in light path at $\lambda > 370$ nm
HOLMIUM	holmium oxide filter for wavelength check
SHUTTER	for measurement of dark current of photo diodes

A photo sensor determines the correct position.

Mirror Assemblies M1 and M2

The instrument contains two spherical mirrors (M1 and M2). The beam adjustable is vertically and horizontally. Both mirrors are identical.

Grating Assembly

The grating separates the light beam into all its component wavelengths and reflects the light onto mirror #2.

The stepper motor reference position is determined by a plate fitted onto the motor shaft, interrupting the beam of a photo sensor. The wavelength calibration of the grating is done at the zero order light position and at 656 nm, which is the emission line of the deuterium lamp.

Beam Splitter Assembly

The beam splitter splits the light beam. One part goes directly to the sample diode. The other part of the light beam goes to the reference diode.

Photo Diodes Assemblies

Two photo diode assemblies are installed in the optical unit. The sample diode assembly is located on the left side of the optical unit. The reference diode assembly is located in the front of the optical unit.

Photo Diode ADC (analog-to-digital converter)

The photo diode current is directly converted to digital data direct photo current digitalization. The data is transferred to the detector main board. The photo diode ADC boards are located close to the photo diodes.

Dual-Wavelength Mode

The detector provides a Dual-Wavelength mode that offers additional operation functions.

Features:

- 200 ms acquisition time per data point
 - 5 Hz data rate distributed to two channels
 - 2.5 Hz data rate for each channel,
- delta wavelength max. 150 nm,
- scans during Dual-Wavelength mode are possible,
- the second order filter is disabled when one wavelength is < 370 nm.

Timetable:

- Wavelength settings are timetable programmable (depends if enough time for implementation is available),
- switching from Single-Wavelength mode to Dual-Wavelength mode is NOT timetable programmable,
- filter settings are not timetable programmable.

Leak and Waste Handling

The Agilent InfinityLab LC Series has been designed for safe leak and waste handling. It is important that all security concepts are understood and instructions are carefully followed.

The solvent cabinet is designed to store a maximum volume of 8 L solvent. The maximum volume for an individual bottle stored in the solvent cabinet should not exceed 2 L. For details, see the usage guideline for the Agilent Infinity II Solvent Cabinets (a printed copy of the guideline has been shipped with the solvent cabinet, electronic copies are available on the Internet).

All leak plane outlets are situated in a consistent position so that all Infinity and Infinity II modules can be stacked on top of each other. Waste tubes are guided through a channel on the right hand side of the instrument, keeping the front access clear from tubes.

The leak plane provides leak management by catching all internal liquid leaks, guiding them to the leak sensor for leak detection, and passing them on to the next module below, if the leak sensor fails. The leak sensor in the leak plane stops the running system as soon as the leak detection level is reached.

Solvent and condensate is guided through the waste channel into the waste container:

- from the detector's flow cell outlet
- from the Multisampler needle wash port
- from the Sample Cooler or Sample Thermostat (condensate)
- from the pump's Seal Wash Sensor (if applicable)
- from the pump's Purge Valve or Multipurpose Valve

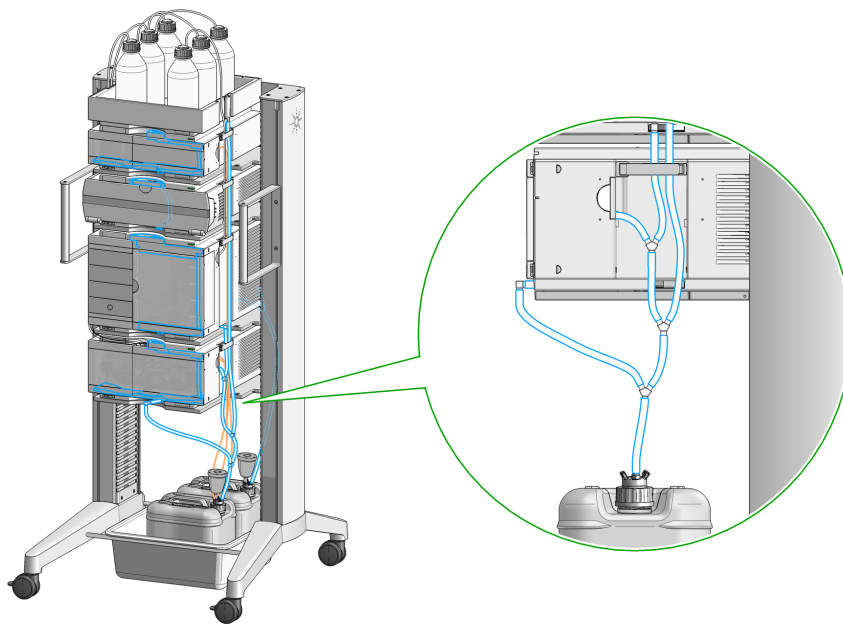

Figure 6 Infinity II Leak Waste Concept (Flex Bench installation)

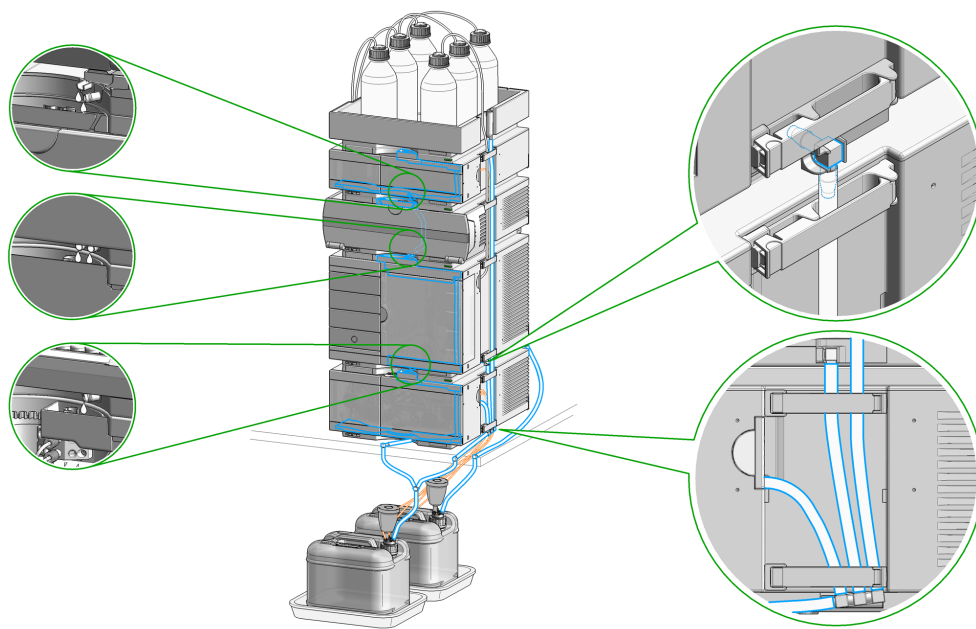

Figure 7 Infinity II Single Stack Leak Waste Concept (bench installation)

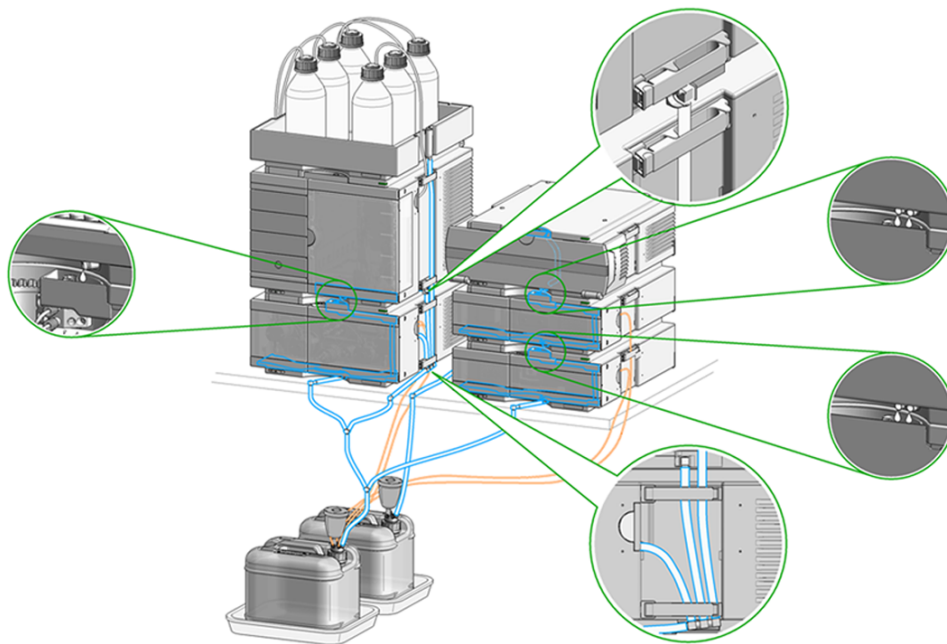

Figure 8 Infinity II Two Stack Leak Waste Concept (bench installation)

The waste tube connected to the leak plane outlet on each of the bottom instruments guides the solvent to a suitable waste container.

Leak Sensor

CAUTION

Solvent incompatibility

The solvent DMF (dimethylformamide) leads to corrosion of the leak sensor. The material of the leak sensor, PVDF (polyvinylidene fluoride), is incompatible with DMF.

- ✓ Do not use DMF as mobile phase.
- ✓ Check the leak sensor regularly for corrosion.

Waste Concept

- 1 Agilent recommends using the 6 L waste can with 1 Stay Safe cap GL45 with 4 ports (5043-1221) for optimal and safe waste disposal. If you decide to use your own waste solution, make sure that the tubes don't immerse in the liquid.

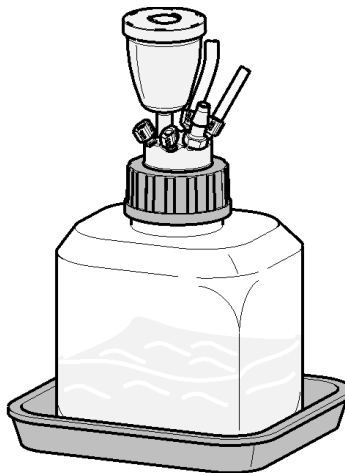

Operating Principle

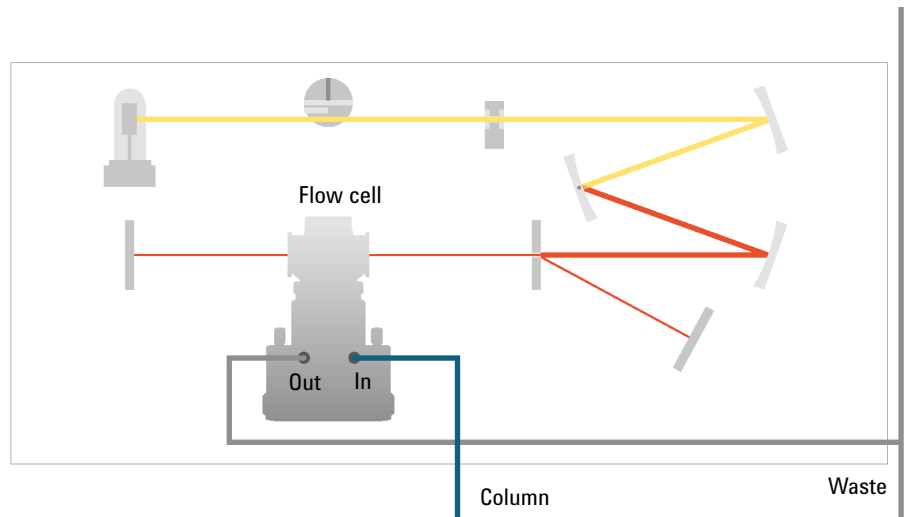

Figure 9 Hydraulic path



2

Site Requirements and Specifications

Site Requirements	26
Physical Specifications	29
Performance Specifications	30
Specifications	30
Specification Conditions	34

This chapter gives information on environmental requirements, physical and performance specifications.

Site Requirements

A suitable environment is important to ensure optimal performance of the instrument.

Power Considerations

The module power supply has wide ranging capability. It accepts any line voltage in the range described in [Table 2](#) on page 29. Consequently there is no voltage selector in the rear of the module. There are also no externally accessible fuses, because automatic electronic fuses are implemented in the power supply.

WARNING

Hazard of electrical shock or damage of your instrumentation can result, if the devices are connected to a line voltage higher than specified.

- ✓ Connect your instrument to the specified line voltage only.

WARNING

Electrical shock hazard

The module is partially energized when switched off, as long as the power cord is plugged in.

The cover protects users from personal injuries, for example electrical shock.

- ✓ Do not open the cover.
- ✓ Do not operate the instrument and disconnect the power cable in case the cover has any signs of damage.
- ✓ Contact Agilent for support and request an instrument repair service.

WARNING

Inaccessible power plug.

In case of emergency it must be possible to disconnect the instrument from the power line at any time.

- ✓ Make sure the power connector of the instrument can be easily reached and unplugged.
- ✓ Provide sufficient space behind the power socket of the instrument to unplug the cable.

Power Cords

Country-specific power cords are available for the module. The female end of all power cords is identical. It plugs into the power-input socket at the rear. The male end of each power cord is different and designed to match the wall socket of a particular country or region.

Agilent makes sure that your instrument is shipped with the power cord that is suitable for your particular country or region.

WARNING**Unintended use of power cords**

Using power cords for unintended purposes can lead to personal injury or damage of electronic equipment.

- ✓ Never use a power cord other than the one that Agilent shipped with this instrument.
- ✓ Never use the power cords that Agilent Technologies supplies with this instrument for any other equipment.
- ✓ Never use cables other than the ones supplied by Agilent Technologies to ensure proper functionality and compliance with safety or EMC regulations.

WARNING**Absence of ground connection**

The absence of ground connection can lead to electric shock or short circuit.

- ✓ Never operate your instrumentation from a power outlet that has no ground connection.

WARNING**Electrical shock hazard**

Solvents may damage electrical cables.

- ✓ Prevent electrical cables from getting in contact with solvents.
 - ✓ Exchange electrical cables after contact with solvents.
-

Bench Space

The detector dimensions and weight (see “Physical Specifications” on page 29) allows you to place the detector on almost any desk or laboratory bench. It needs an additional 2.5 cm (1.0 inch) of space on either side and approximately 8 cm (3.1 inch) in the rear for air circulation and electric connections.

If the bench should carry an Agilent 1200 Infinity Series system, make sure that the bench is designed to bear the weight of all modules.

The detector should be operated in a horizontal position.

Environment

Your detector will work within specifications at ambient temperatures and relative humidity as described in “Physical Specifications” on page 29.

Better drift performance depends on better control of the temperature fluctuations. To realize the highest performance, minimize the frequency and the amplitude of the temperature changes to below 1 °C/hour (1.8 °F/hour). Turbulences around one minute or less can be ignored.

CAUTION

Condensation within the module

Condensation can damage the system electronics.

- ✓ Do not store, ship or use your module under conditions where temperature fluctuations could cause condensation within the module.
 - ✓ If your module was shipped in cold weather, leave it in its box and allow it to warm slowly to room temperature to avoid condensation.
-

Physical Specifications

Table 2 Physical Specifications

Type	Specification	Comments
Weight	11 kg (24.3 lbs)	
Dimensions (height x width x depth)	140 x 396 x 436 mm (5.5 x 15.6 x 17.2 inches)	
Line voltage	100 – 240 V~, ± 10 %	Wide-ranging capability
Line frequency	50 or 60 Hz, ± 5 %	
Power consumption	80 VA, 70 W	
Ambient operating temperature	4 - 55 °C (39 - 131 °F)	
Ambient non-operating temperature	-40 – 70 °C (-40 – 158 °F)	
Humidity	< 95 % r.h. at 40 °C (104 °F)	Non-condensing
Operating altitude	Up to 3000 m (9842 ft)	
Safety standards: IEC, EN, CSA, UL	Overvoltage category II, Pollution degree 2	For indoor use only.
ISM Classification	ISM Group 1 Class B	According to CISPR 11

Performance Specifications

Specifications

Performance Specifications G7114A

Table 3 Performance Specifications G7114A

Type	Specification
Detection type	Double-beam photometer
Light source	Deuterium lamp
Number of signals	Single and dual wavelength detection
Maximum data rate	120 Hz (single wavelength detection) 2.5 Hz (dual wavelength detection)
Short term signal noise (ASTM)	< $\pm 0.25 \cdot 10^{-5}$ AU, at 230 nm (single wavelength detection) < $\pm 0.80 \cdot 10^{-5}$ AU, at 230 nm and 254 nm (dual wavelength detection)
Drift	< $1 \cdot 10^{-4}$ AU/h, at 230 nm
Linear absorbance range	>2.5 AU upper limit
Wavelength range	190 – 600 nm
Wavelength accuracy	± 1 nm, self-calibration with deuterium lines, verification with holmium oxide filter
Wavelength precision	< ± 0.1 nm
Slit width	6.5 nm typical over whole wavelength range
Time programmable	Wavelength, polarity, peak width, lamp on/off

Site Requirements and Specifications

Performance Specifications

Table 3 Performance Specifications G7114A

Type	Specification
Flow cells	<p><i>Standard</i>:14 µL volume, 10 mm cell path length and 40 bar (580 psi) pressure maximum</p> <p><i>Micro</i>:2 µL volume, 3 mm cell path length and 120 bar (1760 psi) pressure maximum</p> <p><i>Semi-micro</i>:5 µL volume, 6 mm cell path length and 40 bar (588 psi) pressure maximum</p> <p><i>Standard Bio</i>:14 µL volume, 10 mm cell path length and 40 bar (580 psi) pressure maximum</p> <p><i>Micro Bio</i>:2 µL volume, 3 mm cell path length and 120 bar (1760 psi) pressure maximum</p> <p><i>Preparative SST</i>:4 µL volume, 3 mm cell path length and 120 bar (1760 psi) pressure maximum</p> <p><i>Preparative Quartz</i>:0.3 mm cell path length and 50 bar (725 psi) pressure maximum</p> <p><i>Preparative Quartz</i>:0.06 mm cell path length and 50 bar (725 psi) pressure maximum</p> <p><i>High pressure</i>:14 µL volume, 10 mm cell path length and 400 bar (5800 psi) pressure maximum</p>
Spectral tools	Stop-flow wavelength scan
Analog output	Recorder/Integrator 100 mV or 1 V, 1 output
Instrument Control	<p>Lab Advisor B.02.08 or above</p> <p>LC and CE Drivers A.02.14 or above</p> <p>For details about supported software versions refer to the compatibility matrix of your version of the LC and CE Drivers</p>
Local Control	Agilent Instant Pilot (G4208A) B.02.19 or above
Communication	<p>LAN, Controller Area Network (CAN), USB</p> <p>Extended Remote Interface: ready, start, stop and shut-down signals</p>
GLP	Early maintenance feedback (EMF) for continuous tracking of instrument usage in terms of lamp burn time with user settable limits and feedback messages. Electronic records of maintenance and errors. RFID for electronic records of flow cell and UV lamp conditions (path length, volume, product number, serial number, test passed, and usage). Verification of wavelength accuracy with built-in holmium oxide filter.
Safety and maintenance	Extensive diagnostics, error detection and display through Agilent Instant Pilot and Agilent Lab Advisor software. Leak detection, safe leak handling, leak output signal for shutdown of pumping system. Low voltages in major maintenance areas. Tracking of flow cells and lamps with RFID (radio frequency identification) tags.
Housing	All materials recyclable.
Others	Second generation of Electronic temperature control (ETC) for the complete optical unit.

Performance Specifications G7114B

Table 4 Performance Specifications G7114B

Type	Specification
Detection type	Double-beam photometer
Light source	Deuterium lamp
Number of signals	Single and dual wavelength detection
Maximum data rate	240 Hz (single wavelength detection) 2.5 Hz (dual wavelength detection)
Short term signal noise (ASTM)	< $\pm 0.15 \cdot 10^{-5}$ AU, at 230 nm (single wavelength detection) < $\pm 0.80 \cdot 10^{-5}$ AU, at 230 nm and 254 nm (dual wavelength detection)
Drift	< $1 \cdot 10^{-4}$ AU/h, at 230 nm
Linear absorbance range	>2.5 AU upper limit
Wavelength range	190 – 600 nm
Wavelength accuracy	± 1 nm, self-calibration with deuterium lines, verification with holmium oxide filter
Wavelength precision	< ± 0.1 nm
Slit width	6.5 nm typical over whole wavelength range
Time programmable	Wavelength, polarity, peak width, lamp on/off
Flow cells	<i>Standard</i> : 14 μ L volume, 10 mm cell path length and 40 bar (580 psi) pressure maximum <i>Micro</i> : 2 μ L volume, 3 mm cell path length and 120 bar (1760 psi) pressure maximum <i>Semi-micro</i> : 5 μ L volume, 6 mm cell path length and 40 bar (580 psi) pressure maximum <i>Standard Bio</i> : 14 μ L volume, 10 mm cell path length and 40 bar (580 psi) pressure maximum <i>Micro Bio</i> : 2 μ L volume, 3 mm cell path length and 120 bar (1760 psi) pressure maximum <i>Preparative SST</i> : 4 μ L volume, 3 mm cell path length and 120 bar (1760 psi) pressure maximum <i>Preparative Quartz</i> : 0.3 mm cell path length and 50 bar (725 psi) pressure maximum <i>Preparative Quartz</i> : 0.06 mm cell path length and 50 bar (725 psi) pressure maximum <i>High pressure</i> : 14 μ L volume, 10 mm cell path length and 400 bar (5800 psi) pressure maximum

Site Requirements and Specifications

Performance Specifications

Table 4 Performance Specifications G7114B

Type	Specification
Spectral tools	Stop-flow wavelength scan
Analog output	Recorder/Integrator 100 mV or 1 V, 1 output
Instrument Control	Lab Advisor B.02.06 or above LC and CE Drivers A.02.11 or above For details about supported software versions refer to the compatibility matrix of your version of the LC and CE Drivers
Local Control	Agilent Instant Pilot (G4208A) B.02.19 or above
Communication	LAN, Controller Area Network (CAN), USB Extended Remote Interface: ready, start, stop and shut-down signals
GLP	Early maintenance feedback (EMF) for continuous tracking of instrument usage in terms of lamp burn time with user settable limits and feedback messages. Electronic records of maintenance and errors. RFID for electronics records of flow cell and UV lamp conditions (path length, volume, product number, serial number, test passed, and usage). Verification of wavelength accuracy with built-in holmium oxide filter.
Safety and maintenance	Extensive diagnostics, error detection and display through Agilent Instant Pilot and Agilent Lab Advisor software. Leak detection, safe leak handling, leak output signal for shutdown of pumping system. Low voltages in major maintenance areas. Tracking of flow cells and lamps with RFID (radio frequency identification) tags.
Housing	All materials recyclable.
Others	Second generation of Electronic temperature control (ETC) for the complete optical unit.

Specification Conditions

ASTM: "Standard Practice for Variable Wavelength Photometric Detectors Used in Liquid Chromatography".

Reference conditions: Standard flow cell, path length 10 mm, flow 1 mL/min LC-grade methanol.

Noise:

$\pm 1.5 \cdot 10^{-6}$ AU at 230 nm, TC 2 s

RT = 2.2 * TC

Linearity:

Linearity is measured with caffeine at 265 nm.

NOTE

The specifications are based on the standard RFID tag lamp (G1314-60101) and may not be achieved when other lamp types or aged lamps are used.

ASTM drift tests require a temperature change below 2°C/hour (3.6°F/hour) over one hour period. Our published drift specification is based on these conditions. Larger ambient temperature changes will result in larger drift.

Better drift performance depends on better control of the temperature fluctuations. To realize the highest performance, minimize the frequency and the amplitude of the temperature changes to below 1°C/hour (1.8°F/hour). Turbulences around one minute or less can be ignored.

Performance tests should be done with a completely warmed up optical unit (> one hour). ASTM measurements require that the detector should be turned on at least 24 hours before start of testing.



3 Using the Module

Magnets	36
Turn on/off	37
Status Indicators	39
Instrument Configuration	40
Set up the Detector with Agilent Open Lab ChemStation	42
The Detector User Interface	43
Detector Control Settings	45
Method Parameter Settings	46
Scanning with the VWD	50
Agilent Local Control Modules	52

This chapter explains the essential operational parameters of the module.

Magnets

- 1 Magnets in doors of pumps, autosamplers, detectors, and fraction collectors.

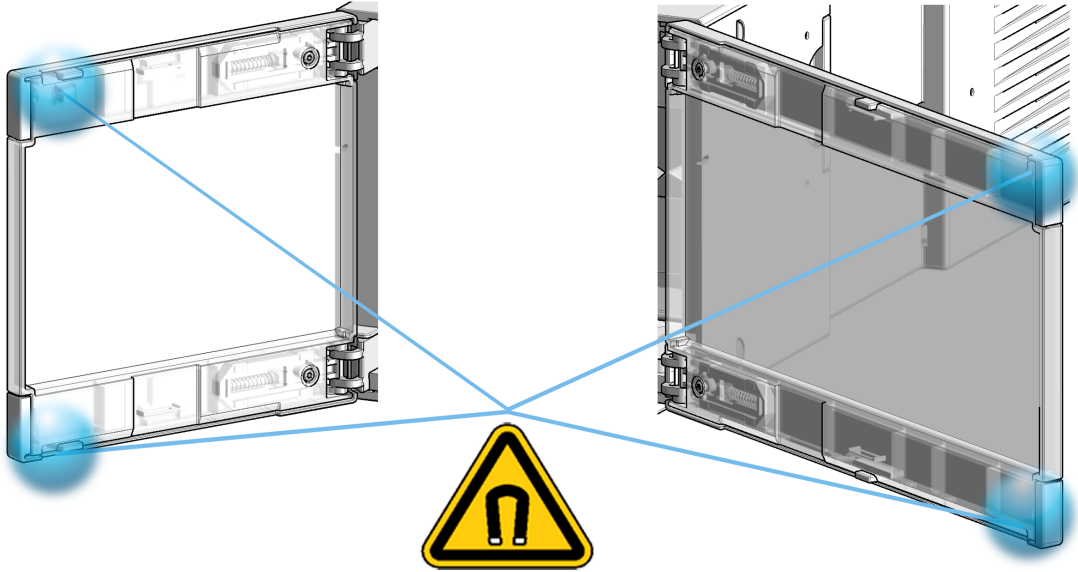

Turn on/off

This procedure exemplarily shows an arbitrary LC stack configuration.

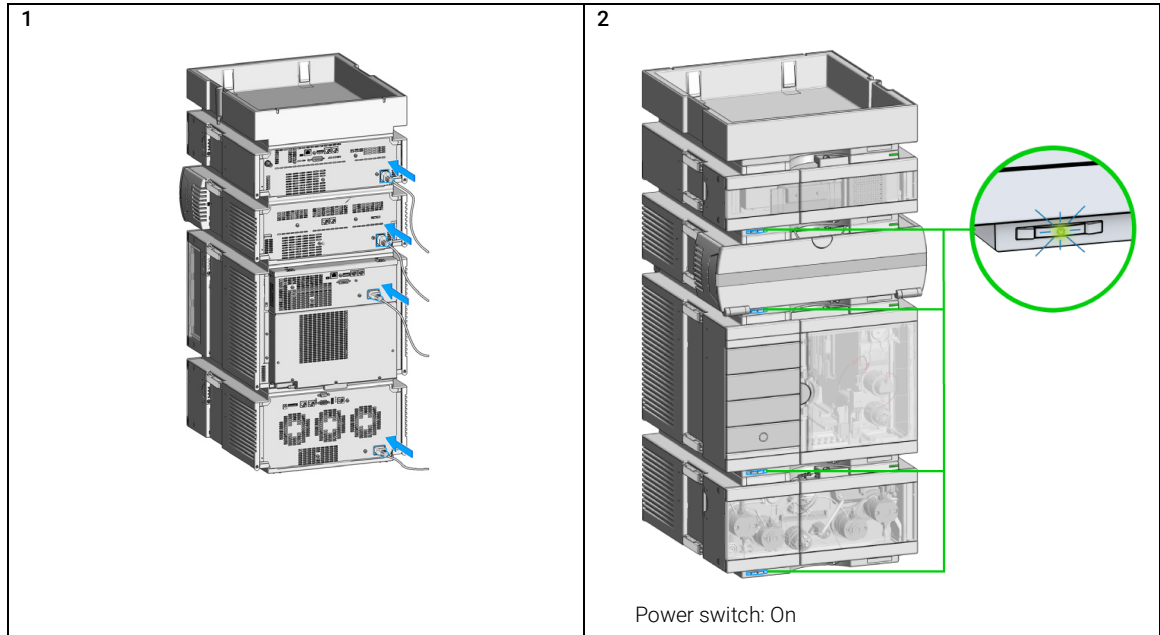

Using the Module

Turn on/off

3 Turn instrument **On/Off** with the control software.

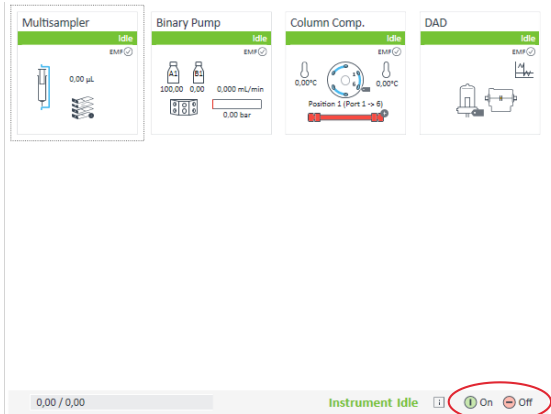

4

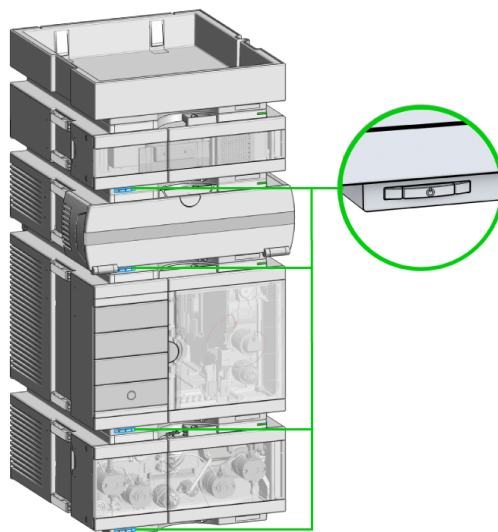

Power switch: Off

5

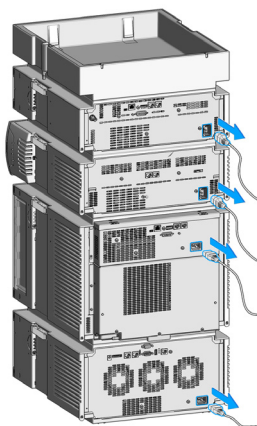

Status Indicators

This procedure exemplarily shows an arbitrary LC stack configuration.

- 1 The module status indicator indicates one of six possible module conditions:

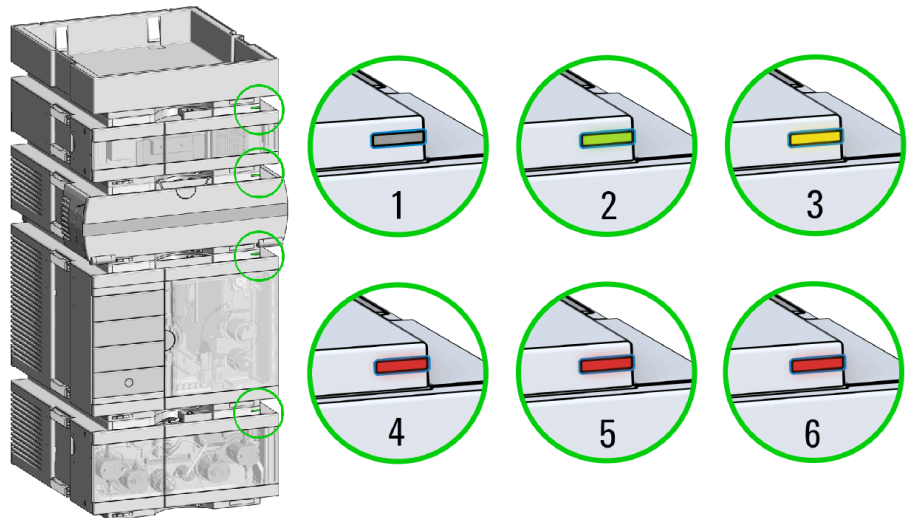

Status indicators

1. Idle
2. Run mode
3. Not-ready. Waiting for a specific pre-run condition to be reached or completed.
4. Error mode - interrupts the analysis and requires attention (for example, a leak or defective internal components).
5. Resident mode (blinking) - for example, during update of main firmware.
6. Bootloader mode (fast blinking). Try to re-boot the module or try a cold-start. Then try a firmware update.

Instrument Configuration

- 1 Set the switches of the Configuration switch at the rear of the module:
 - a All switches DOWN: module uses the default IP address 192.168.254.11.



- b Switch 4 UP and others DOWN: module uses DHCP.
 - c Switch 5 UP and others DOWN: modules uses STORED address.

Using the Module Instrument Configuration

- 2 Enter the setup information (MAC / IP address and/or Instrument Name).
 - a Agilent OpenLab ChemStation (Configure Instrument):

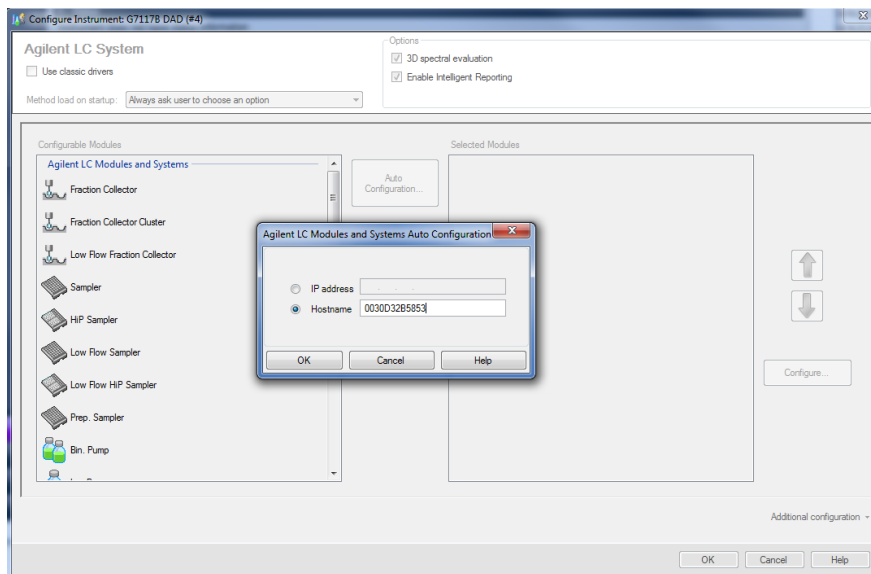

- b Lab Advisor (Instrument Overview - Add Instrument):

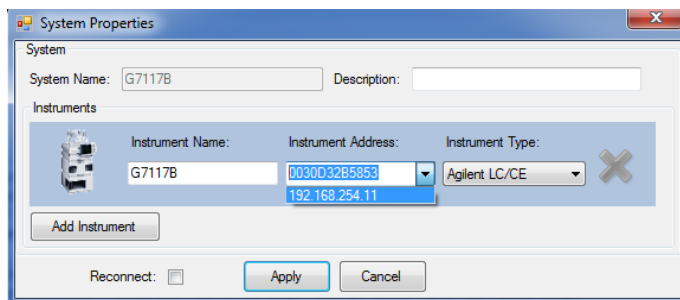

Set up the Detector with Agilent Open Lab ChemStation

The setup of the detector is shown with the Agilent OpenLab ChemStation C.01.07 and Driver A.02.14.

NOTE

This section describes the detector settings only. For information on the Agilent OpenLab ChemStation or other 1200 Infinity modules refer to the corresponding documentation.

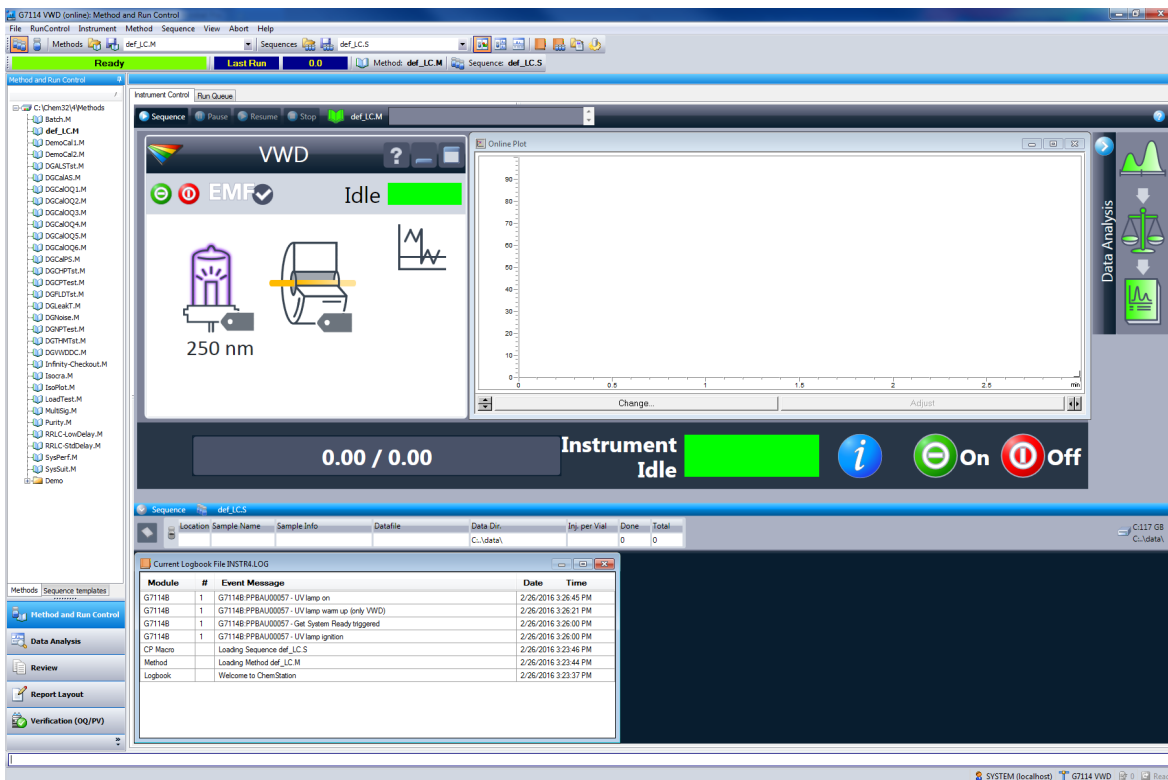
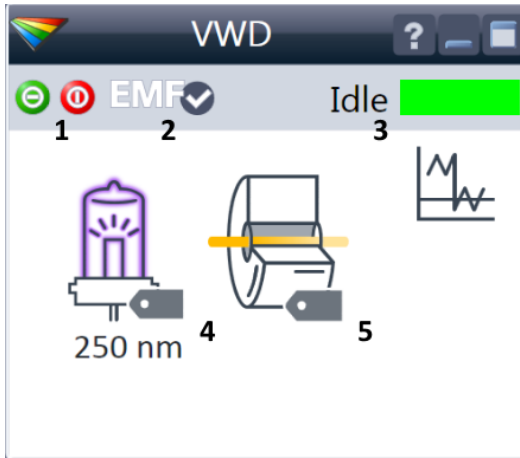

Figure 10 ChemStation Method and Run Control (just detector is shown)

After successful load of the OpenLab ChemStation, you should see the module as an active item in the graphical user interface (GUI).

The Detector User Interface



Within the detector GUI, there are active areas. If you move the mouse cursor across the icons the cursor will change.

- 1 Lamp: turn on and off of UV-lamp
- 2 EMF status
- 3 Detector status
- 4 Lamp status (on/off) and information (RFID tag)
- 5 Flow Cell information (RFID tag)

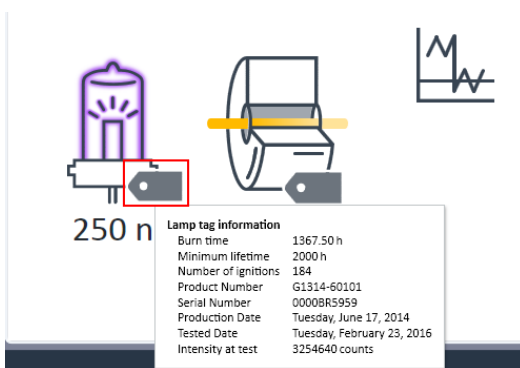

RFID tag information is displayed when moving with the mouse cursor on to the tag attached to the flow cell or lamp. The information provides flow cell and lamp related information like

- Part number
 - Production date
 - Serial number
- and other details.

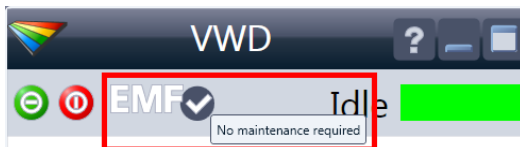

EMF Status shows Run / Ready / Error state and "Not Ready text" or "Error text"

- Offline (gray)
- Ok. No Maintenance required (green)
- EMF warning. Maintenance might be required (yellow)
- EMF warning. Maintenance required (red)

Important: The EMF settings can be accessed via Agilent Lab Advisor. The limit(s) can be changed. Based on the limit, the User Interface displays the above status.



Module Status shows Run / Ready / Error state and "Not Ready text" or "Error text"

- Error (red)
- Not ready (yellow)
- Ready (green)
- Pre run, Post run (purple)
- Run (blue)
- Idle (green)
- Offline (dark gray)
- Standby (light gray)

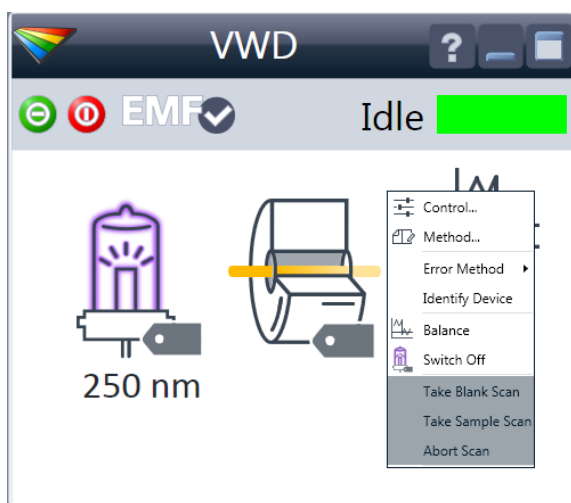

A right-click into the Active Area will open a menu to

- Show the Control Interface (special module settings)
- Show the Method interface (similar as via menu **Instrument > Setup Instrument Method**)
- Set Error Method
- Identify Module (Status LED will blink)
- Perform a Balance
- Switch the UV-lamp on/off (same as click on button "Make Device Ready/Turn device off (standby)")
- Take / Abort Scans (during flow off)

Detector Control Settings

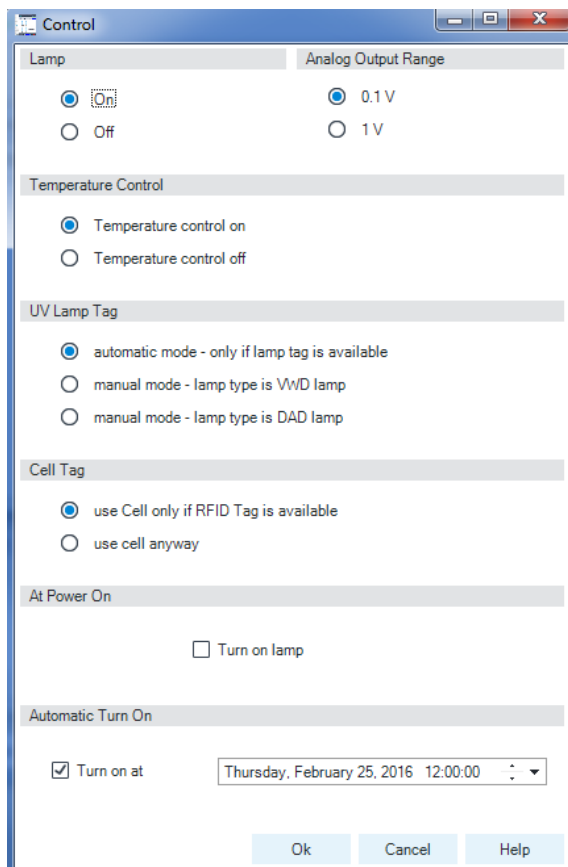

The figure shows the default settings.

- **Lamps:** can be turned ON/OFF.
 - **Analog Output Range:** can be set to either 100 mV or 1 V full scale, for additional settings see **"Analog"** (under Table 5 on page 47).
 - **Temperature Control:** The optical unit is kept on constant temperature (some degrees above ambient) and improves the baseline stability in unstable environments, see also **"Environment"** on page 28.
- If the flow cell temperature is critical for your chromatography or your environment is stable, you may set the Temperature Control to off. This will lower the optical unit and flow cell temperature by some degree.
- **UV Lamp Tag**
 - **Automatic** detects a lamp with RFID tag. If no RFID tag lamp is used, "UV lamp not ready" is displayed and it cannot be ignited. A compatible mode has to be selected based on the used lamp; see Non-RFID-tag lamp information below.
 - **Manual** (by PN) uses the selected "heating" mode. This mode can also be used when the RFID tag of the standard lamp (Deuterium lamp (with RFID tag) (G1314-60101)) is not recognized (defect RFID tag or reader).
 - **Non-RFID-tag lamp:** In case a non-RFID-tag lamp is used, the user interface will show this when selecting a compatible mode. You may operate the detector outside of the guaranteed specification. The correct selection is important for optimal performance and lifetime.
 - **Cell Tag:** Automatic mode for Agilent flow cells with RFID tags. If no RFID tag cell is used, detector icon will become gray (cell tag not ready) and analysis is disabled.
 - **At Power On:** automatic lamp-on at power on.
 - **Automatic Turn On:** automatic detector power on.

Method Parameter Settings

These settings are available via **Menu > Instrument > Set up Instrument Method** or via right click into the module's active area (does not show the **Instrument Curves** tab).

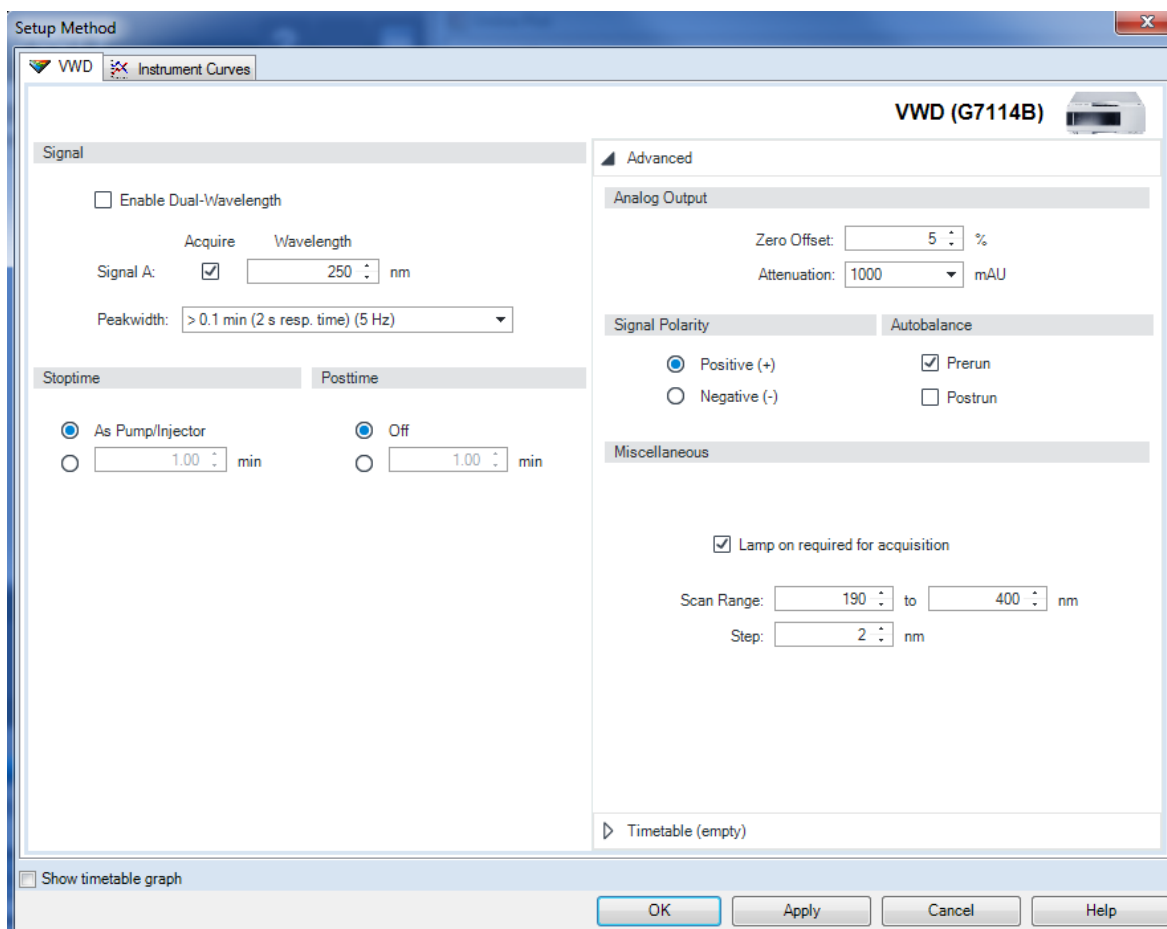

Figure 11 Method parameter settings

NOTE

For additional help and support: Highlight the desired cell and press **F1**. A help screen will open with additional information and documentation about the topic.

Table 5 Method Parameter Settings

Figure 12 G7114B Peakwidth settings up to 240 Hz

Figure 13 G7114A Peakwidth settings up to 120 Hz

Figure 14 G7114B Dual Wavelength Settings

Signal

Wavelength

Single Wavelength (190 – 600 nm, step 1)

Dual Wavelength Mode enables the multi-wavelength mode with two wavelengths.

Peakwidth (Response time, Data Rate)

Peakwidth enables you to select the peak width (response time) for your analysis. The peak width is defined as the width of a peak, in minutes, at half the peak height. Set the peak width to the narrowest expected peak in your chromatogram.

The peak width sets the optimum response time for your detector. The peak detector ignores any peaks that are considerably narrower, or wider, than the peak width setting. The response time is the time between 10 % and 90 % of the output signal in response to an input step function. When the All spectrum storage option is selected, then spectra are acquired continuously depending on the setting of the peak width. The time specified by the peak width is used as a factor in the acquisition of spectra. The acquisition time for one spectrum is slightly less than the peak width divided by 8, which is the acquisition time.

Limits: When you set the peak width (in minutes), the corresponding response time is set automatically and the appropriate data rate for signal and spectra acquisition is selected.

NOTE

The G7114A VWD has a data rate of up to 120 Hz. The G7114B VWD has a data rate of up to 240 Hz.

Table 5 Method Parameter Settings

Stoptime		Posttime	
<input checked="" type="radio"/> As Pump/Injector	<input type="radio"/> 1.00 min	<input checked="" type="radio"/> Off	<input type="radio"/> 1.00 min
Analog Output			
Zero Offset: 5 %		Attenuation: 1000 mAU	
Signal Polarity		Autobalance	
<input checked="" type="radio"/> Positive (+)	<input type="radio"/> Negative (-)	<input checked="" type="checkbox"/> Prerun	<input type="checkbox"/> Postrun
Miscellaneous			
<input checked="" type="checkbox"/> Lamp on required for acquisition			
Scan Range: 190 to 400 nm		Step: 2 nm	

Stoptime/Posttime

The stoptime is the time where either the complete system stops (**As Pump/Injector**) or the module (if different from system stop time). The data collection is stopped at this time. A posttime period can be used to allow module's items to equilibrate (e.g. after gradient change or temperature change).

Analog Output

The range can be set to either 100 mV or 1 V full scale, see [Table](#) on page 45.

- **Zero Offset:** 1 – 99 % in steps of 1 % (5 % equal to 50 mV).
- **Attenuation:** 0.98 – 4000 mAU at discrete values for either 100 mV or 1 V full scale.

Signal Polarity

Can be switched to negative (if required).

Autobalance

Defines, whether a balance is performed prior to a run and/or after a run has finished.

Miscellaneous

Lamp on required for acquisition: If unchecked, the lamp will be turned off after the analysis has finished. Note that the lamp on requires at least one hour warm-up time, see [“Warm up of the Detector”](#) on page 83.

Scan Range / Step: Stop-Flow scan range / step. Access to the scan feature is only possible during run. See [“Scanning with the VWD”](#) on page 50.

Table 5 Method Parameter Settings

▲ Timetable (1/100 events)		
Time [min]	Function	Parameter
▶ 0.00	Balance	Autobalancing
	Balance	
	Change Signal	
	Take Scan	

Timetable

You may set up time events to change functions with their parameters over the run time. Add lines as required.

Time Limits: 0.00 to 99999.00 min in steps of 0.01 min.

Via the buttons in the bottom area, time table lines can be added, removed, cut copied, pasted or completely cleared. Based on the chosen function, a certain parameter can be selected.

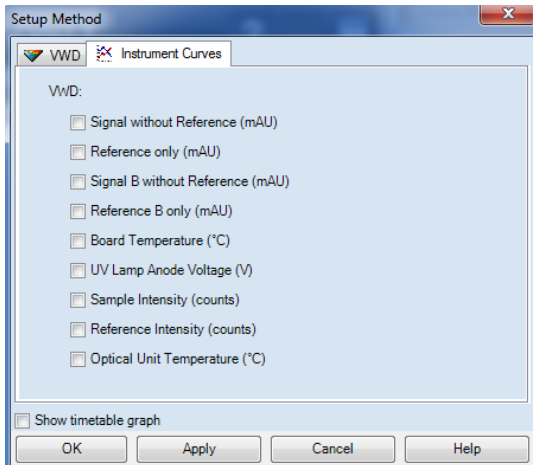
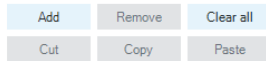

Instrument Curves

The detector has several signals (internal temperatures, voltages of lamps) that can be used for diagnosing problems. These can be baseline problems deriving from deuterium lamps wander / drift problems due to temperature changes. These signals can be used in addition to the normal baseline signal to determine whether correlation to temperature or voltage/current of the lamp.

These signals are available via the Agilent ChemStation Online Plot/Data Signal and/or Agilent Lab Advisor Software.

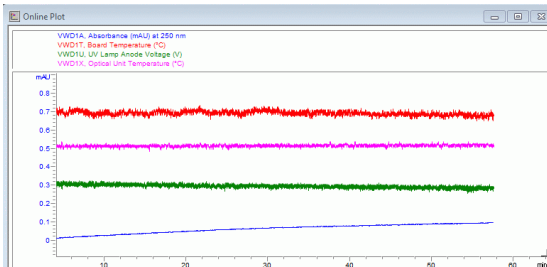

Scanning with the VWD

NOTE

Access to the scan feature is only possible during run with stopped flow. The spectrum is taken during a stop-flow condition only while the peak is kept in the flow cell.

- 1 Set up a run.
- 2 Start a run.
- 3 While running on the baseline, take a **Blank Scan**. A background scan is stored in the memory.

Table 6 Blank scan

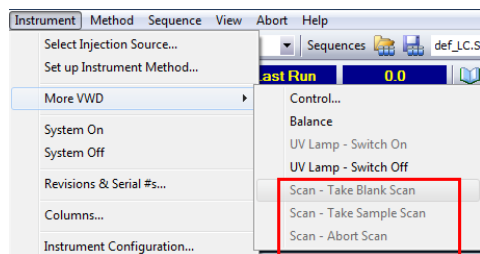

- Step 1: Blank Scan: scan of the background (solvent) is stored in the memory.
 - Step 2: Sample Scan: scan of the peak of interest is taken while the peak stays in the flow cell (stop-flow condition).
 - Online Spectrum: Sample Scan minus Blank Scan.
- Here the functions are inactive (grayed out). Will be active in run mode.

- 4 When the peak of interest enters the flow cell, stop the flow (set flow rate to zero or open the purge valve) and wait a few moments to stabilize the concentration.

NOTE

Turning off the pump would stop the run and no access to the sample scan is possible.

Using the Module

Scanning with the VWD

- 5 Open the Online Spectra window (**View > Online Spectra > VWD**) and change the absorbance and wavelength range according to your needs.

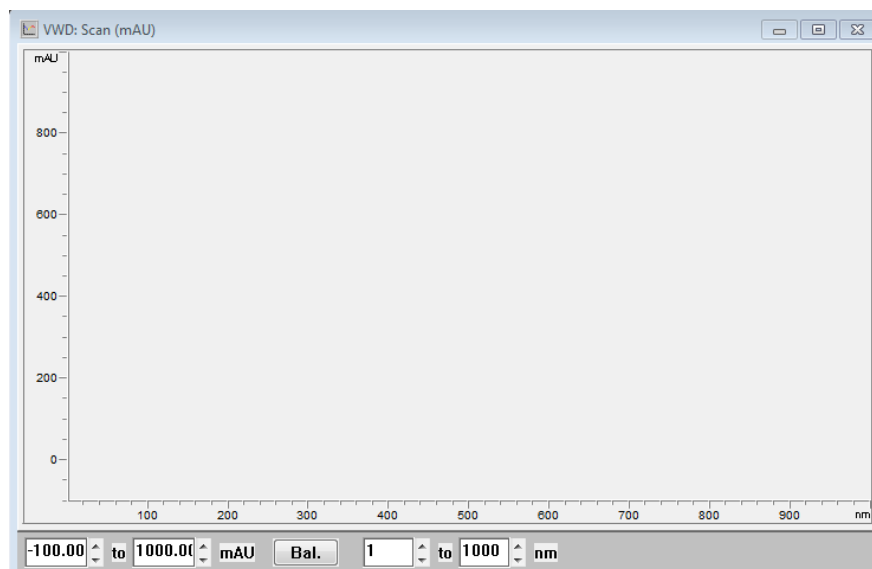

Figure 15 Online Spectra Window

- 6 Select **Sample Scan**. A sample scan is taken in the range defined under **Miscellaneous** in Table 5 on page 47 and displays the result (Sample Scan minus Blank Scan).

Agilent Local Control Modules

Agilent InfinityLab Companion G7108AA

The Agilent InfinityLab Companion gives you complete control, system monitoring, signal plotting, and diagnostic capabilities for a wide range of LC system modules.

The instrument control solution is available as full package including all hardware and accessories, but can also be used on your own mobile devices like tablets, mobile phones and other electronic equipment.

Combining the conveniences of the Agilent Instant Pilot features with state-of-the-art mobile technology, the Agilent InfinityLab Companion gives you maximum flexibility and ease of use to control and monitor your LC system modules.

Features:

- Complete local control and monitoring of Agilent Infinity II LC modules
- Excellent usability and ease of use through a user interface specifically tailored for mobile devices - simple, intuitive touch-enabled, and visual controllable.
- High flexibility through a modern "Bring your own device" approach. Connection between LC module and mobile device either wireless via Wi-Fi or wired over USB cable (with full package).
- Convenient, ergonomic operation either handheld or attached to a module at the stack with newly developed, secure tablet holder (included in the full package).
- Preconfigured tablet with all required software already installed (included in the full package).
- Centerpiece of the solution is a USB dongle that activates the complete intelligence of the InfinityLab Companion on the instrument stack.

The InfinityLab Companion provides:

- fast and direct control in front of the instrument
- a clear overview of the system status
- control functionalities
- access to method parameters and sequences
- a logbook showing events from the modules
- diagnostic tests

4 Preparing the Module

Leak and Waste Handling	54
Waste Concept	55
Setting up an Analysis	56
Before Using the System	56
Requirements and Conditions	58
Preparing the Detector	60
Preparing the HPLC System	60
Running the Sample and Verifying the Results	62
Solvent Information	63
Capillary Coding Guide	69
Syntax for Capillary Description	69
At-a-Glance Color-Coding Keys	71
Installing Capillaries	72

This chapter provides information on how to set up the detector for an analysis and explains the basic settings.

Leak and Waste Handling

WARNING

Toxic, flammable and hazardous solvents, samples and reagents

The handling of solvents, samples and reagents can hold health and safety risks.

- ✓ When working with these substances observe appropriate safety procedures (for example by wearing goggles, safety gloves and protective clothing) as described in the material handling and safety data sheet supplied by the vendor, and follow good laboratory practice.
- ✓ Do not use solvents with an auto-ignition temperature below 200 °C (392 °F). Do not use solvents with a boiling point below 56 °C (133 °F).
- ✓ Avoid high vapor concentrations. Keep the solvent temperature at least 40 °C (72 °F) below the boiling point of the solvent used. This includes the solvent temperature in the sample compartment. For the solvents methanol and ethanol keep the solvent temperature at least 25 °C (45 °F) below the boiling point.
- ✓ Do not operate the instrument in an explosive atmosphere.
- ✓ Do not use solvents of ignition Class IIC according IEC 60079-20-1 (for example, carbon disulfide).
- ✓ Reduce the volume of substances to the minimum required for the analysis.
- ✓ Never exceed the maximum permissible volume of solvents (8 L) in the solvent cabinet. Do not use bottles that exceed the maximum permissible volume as specified in the usage guideline for solvent cabinet.
- ✓ Ground the waste container.
- ✓ Regularly check the filling level of the waste container. The residual free volume in the waste container must be large enough to collect the waste liquid.
- ✓ To achieve maximal safety, regularly check the tubing for correct installation.

NOTE

For details, see the usage guideline for the solvent cabinet. A printed copy of the guideline has been shipped with the solvent cabinet, electronic copies are available in the Agilent Information Center or via the Internet.

For details on correct installation, see separate installation documentation.

Waste Concept

- 1 Agilent recommends using the 6 L waste can with 1 Stay Safe cap GL45 with 4 ports (5043-1221) for optimal and safe waste disposal. If you decide to use your own waste solution, make sure that the tubes don't immerse in the liquid.



Setting up an Analysis

This chapter can be used for

- preparing the system,
- to learn the set up of an HPLC analysis and
- to use it as an instrument check to demonstrate that all modules of the system are correctly installed and connected. It is not a test of the instrument performance.
- Learn about special settings

Before Using the System

Solvent Information

Observe recommendations on the use of solvents in chapter “Solvents” in the pump’s reference manual.

Priming and Purging the System

When the solvents have been exchanged or the pumping system has been turned off for a certain time (for example, overnight) oxygen will re-diffuse into the solvent channel between the solvent reservoir, vacuum degasser (when available in the system) and the pump. Solvents containing volatile ingredients will slightly lose these. Therefore priming of the pumping system is required before starting an application.

Table 7 Choice of Priming Solvents for Different Purposes

Activity	Solvent	Comments
After an installation	Isopropanol	Best solvent to flush air out of the system
When switching between reverse phase and normal phase (both times)	Isopropanol	Best solvent to flush air out of the system
After an installation	Ethanol or Methanol	Alternative to Isopropanol (second choice) if no Isopropanol is available
To clean the system when using buffers	Bidistilled water	Best solvent to re-dissolve buffer crystals
After a solvent change	Bidistilled water	Best solvent to re-dissolve buffer crystals
After the installation of normal phase seals (P/N 0905-1420)	Hexane + 5% Isopropanol	Good wetting properties

NOTE

The pump should never be used for priming empty tubings (never let the pump run dry). Use a syringe to draw enough solvent for completely filling the tubings to the pump inlet before continuing to prime with the pump.

- 1 Open the purge valve of your pump (by turning it counterclockwise) and set flow rate to 3 – 5 mL/min.
- 2 Flush all tubes with at least 30 mL of solvent.
- 3 Set flow to required value of your application and close the purge valve.

NOTE

Pump for approximately 10minutes before starting your application.

Requirements and Conditions

What You Will Need

The table below lists the items you need to have for the set up of the analysis. Some of these are optional (not required for the basic system).

Table 8 What you will need

Agilent 1200 Infinity Series system	Pump (plus degassing)
	Autosampler
	Detector, standard flow cell installed
	Degasser (optional)
	Column Compartment (optional)
	Agilent CDS
	System should be correctly set up for LAN communication with the Agilent ChemStation
Column:	Zorbax Eclipse XDB-C18, 4.6 x 150 mm, 5 μ m (993967-902) or an equivalent column
Standard:	Agilent isocratic checkout sample (01080-68704)

Conditions

A single injection of the isocratic test standard is made under the conditions given in [Table 9](#) on page 58:

Table 9 Conditions

Flow	1.5 mL/min
Stoptime	8 min
Solvent	100% (30% water/70% Acetonitrile)
Temperature	Ambient
Wavelength	sample 254 nm
Injection Volume	1 μ L
Column Temperature (optional):	25 °C or ambient

Typical Chromatogram

A typical chromatogram for this analysis is shown in [Figure 16](#) on page 59. The exact profile of the chromatogram will depend on the chromatographic conditions. Variations in solvent quality, column packing, standard concentration and column temperature will all have a potential effect on peak retention and response.

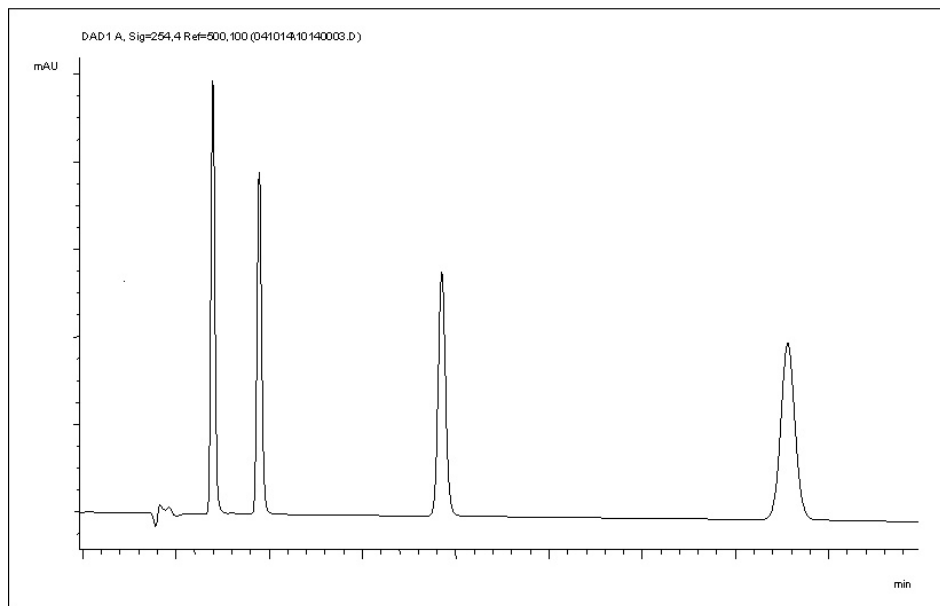

Figure 16 Typical Chromatogram with UV-detector

Preparing the Detector

For best performance of the detector

- Let the lamp warm-up and stabilize for at least one hour (initial turn on of the module requires a longer time depending on the environment and the application needs); refer to “[Specification Conditions](#)” on page 34.
- For high sensitivity measurements, a stable environment is required; refer to “[Environment](#)” on page 28. Prevent drafts from air condition systems.
- Do not work with removed/open front panels/doors. When the system includes a G1316 TCC (typically located below the detector) and its front panel is removed while the TCC is set to high temperatures, the up-streaming air could influence the stability of the detector baseline.

Preparing the HPLC System

- 1 Turn on the control software and the monitor.
- 2 Turn on the modules.
- 3 Start the control software. The screen should show all modules and the system status is Not Ready.
- 4 Turn on the modules that require conditioning:
 - a Detector lamp (warm-up for at least 60 min to get a stable baseline).
 - b Column compartment (set temperature as required).
 - c Pump (purge).
 - d Sampler (prepare the standard isocratic sample into a vial).
 - e Solvents (fill water and Acetonitrile into the solvent bottles).
- 5 Load the default method.
- 6 Pump the water/acetonitrile (30/70 %) mobile phase through the column for 10 min for equilibration.

Preparing the Module

Setting up an Analysis

- 7 Select the menu item **Run Control > Sample Info** and enter information about this application. Click **OK** to leave this screen.

Sample Info: WADI1171

Operator name: SYSTEM

Data file

Path: D:\Agilent\ChemStation\DATA\ Subdirectory: G7117

Name Pattern

Signal 1: <SampleName> <Date> <Time>
Isocratic Sample 2014-08-27 10-42-06.D

Sample parameters

Vial/Location: 1 (blank run if no entry)

Sample name: Isocratic Sample Sample amount: 0

Multiplier: 1 Dilution: 1 ISTD amount: 0

Comment: Isocratic Sample

Custom Fields ... Run Method OK Cancel Help

Figure 17 Sample Info

Running the Sample and Verifying the Results

- 1 To start a run select the menu item **RunControl > Run Method**.
- 2 This will start the modules and the online plot on the Agilent ChemStation will show the resulting chromatogram.

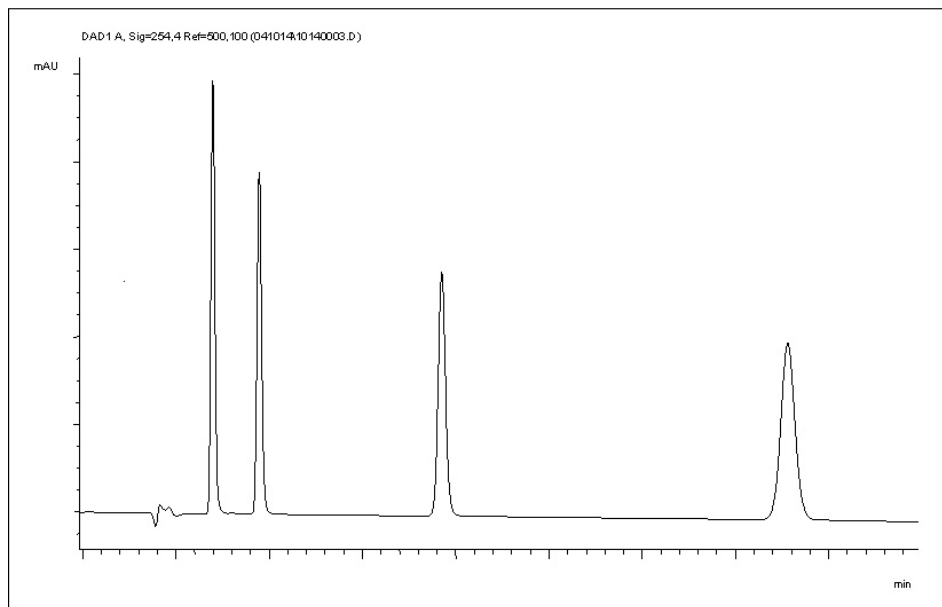

Figure 18 Chromatogram with Isocratic Test Sample

NOTE

Information about using the Data Analysis functions can be obtained from the Using your ChemStation manual supplied with your system.

Solvent Information

Observe the following recommendations on the use of solvents.

- Follow the recommendations for avoiding the growth of algae, see the pump manuals.
- Small particles can permanently block capillaries and valves. Therefore, always filter solvents through 0.22 µm filters.
- Avoid or minimize the use of solvents that may corrode parts in the flow path. Consider specifications for the pH range given for different materials such as flow cells, valve materials etc. and recommendations in subsequent sections.

General Information about Solvent/Material Compatibility

Materials in the flow path are carefully selected based on Agilent's experiences in developing highest-quality instruments for HPLC analysis over several decades. These materials exhibit excellent robustness under typical HPLC conditions. For any special condition, please consult the material information section or contact Agilent.

Disclaimer

Subsequent data was collected from external resources and is meant as a reference. Agilent cannot guarantee the correctness and completeness of such information. Data is based on compatibility libraries, which are not specific for estimating the long-term life time under specific but highly variable conditions of UHPLC systems, solvents, solvent mixtures and samples. Information can also not be generalized due to catalytic effects of impurities like metal ions, complexing agents, oxygen etc. Apart from pure chemical corrosion, other effects like electro corrosion, electrostatic charging (especially for non-conductive organic solvents), swelling of polymer parts etc. need to be considered. Most data available refers to room temperature (typically 20 – 25 °C, 68 – 77 °F). If corrosion is possible, it usually accelerates at higher temperatures. If in doubt, please consult technical literature on chemical compatibility of materials.

MP35N

MP35N is a nonmagnetic, nickel-cobalt-chromium-molybdenum alloy demonstrating excellent corrosion resistance (for example, against nitric and sulfuric acids, sodium hydroxide, and seawater) over a wide range of concentrations and temperatures. In addition, this alloy shows exceptional resistance to high-temperature oxidation. Due to excellent chemical resistance and toughness, the alloy is used in diverse applications: dental products, medical devices, nonmagnetic electrical components, chemical and food processing equipment, marine equipment. Treatment of MP35N alloy samples with 10 % NaCl in HCl (pH 2.0) does not reveal any detectable corrosion. MP35N also demonstrates excellent corrosion resistance in a humid environment. Although the influence of a broad variety of solvents and conditions has been tested, users should keep in mind that multiple factors can affect corrosion rates, such as temperature, concentration, pH, impurities, stress, surface finish, and dissimilar metal contacts.

Polyphenylene Sulfide (PPS)

Polyphenylene sulfide has outstanding stability even at elevated temperatures. It is resistant to dilute solutions of most inorganic acids, but it can be attacked by some organic compounds and oxidizing reagents. Nonoxidizing inorganic acids, such as sulfuric acid and phosphoric acid, have little effect on polyphenylene sulfide, but at high concentrations and temperatures, they can still cause material damage. Nonoxidizing organic chemicals generally have little effect on polyphenylene sulfide stability, but amines, aromatic compounds, and halogenated compounds may cause some swelling and softening over extended periods of time at elevated temperatures. Strong oxidizing acids, such as nitric acid (> 0.1 %), hydrogen halides (> 0.1 %), peroxy acids (> 1 %), or chlorosulfuric acid degrade polyphenylene sulfide. It is not recommended to use polyphenylene sulfide with oxidizing material, such as sodium hypochlorite and hydrogen peroxide. However, under mild environmental conditions, at low concentrations and for short exposure times, polyphenylene sulfide can withstand these chemicals, for example, as ingredients of common disinfectant solutions.

PEEK

PEEK (Polyether-Ether Ketones) combines excellent properties regarding biocompatibility, chemical resistance, mechanical and thermal stability. PEEK is therefore the material of choice for UHPLC and biochemical instrumentation.

It is stable in the specified pH range (for the Bio-Inert LC system: pH 1 – 13, see bio-inert module manuals for details), and inert to many common solvents.

There is still a number of known incompatibilities with chemicals such as chloroform, methylene chloride, THF, DMSO, strong acids (nitric acid > 10 %, sulfuric acid > 10 %, sulfonic acids, trichloroacetic acid), halogens or aqueous halogen solutions, phenol and derivatives (cresols, salicylic acid, and so on).

When used above room temperature, PEEK is sensitive to bases and various organic solvents, which can cause it to swell. Under such conditions, normal PEEK capillaries are sensitive to high pressure. Therefore, Agilent uses stainless steel clad PEEK capillaries in bio-inert systems. The use of stainless steel clad PEEK capillaries keeps the flow path free of steel and ensures pressure stability up to 600 bar. If in doubt, consult the available literature about the chemical compatibility of PEEK.

Polyimide

Agilent uses semi-crystalline polyimide for rotor seals in valves and needle seats in autosamplers. One supplier of polyimide is DuPont, which brands polyimide as Vespel, which is also used by Agilent.

Polyimide is stable in a pH range between 1 and 10 and in most organic solvents. It is incompatible with concentrated mineral acids (e.g. sulphuric acid), glacial acetic acid, DMSO and THF. It is also degraded by nucleophilic substances like ammonia (e.g. ammonium salts in basic conditions) or acetates.

Polyethylene (PE)

Agilent uses UHMW (ultra-high molecular weight)-PE/PTFE blends for yellow piston and wash seals, which are used in 1290 Infinity pumps, 1290 Infinity II pumps, the G7104C and for normal phase applications in 1260 Infinity pumps.

Polyethylene has a good stability for most common inorganic solvents including acids and bases in a pH range of 1 to 12.5. It is compatible with many organic solvents used in chromatographic systems like methanol, acetonitrile and isopropanol. It has limited stability with aliphatic, aromatic and halogenated hydrocarbons, THF, phenol and derivatives, concentrated acids and bases. For normal phase applications, the maximum pressure should be limited to 200 bar.

Tantalum (Ta)

Tantalum is inert to most common HPLC solvents and almost all acids except fluoric acid and acids with free sulfur trioxide. It can be corroded by strong bases (e.g. hydroxide solutions > 10 %, diethylamine). It is not recommended for the use with fluoric acid and fluorides.

Stainless Steel (SST)

Stainless steel is inert against many common solvents. It is stable in the presence of acids and bases in a pH range of 1 to 12.5. It can be corroded by acids below pH 2.3. It can also corrode in following solvents:

- Solutions of alkali halides, their respective acids (for example, lithium iodide, potassium chloride, and so on) and aqueous solutions of halogens.
- High concentrations of inorganic acids like nitric acid, sulfuric acid and organic solvents especially at higher temperatures (replace, if your chromatography method allows, by phosphoric acid or phosphate buffer which are less corrosive against stainless steel).
- Halogenated solvents or mixtures which form radicals and/or acids, for example:

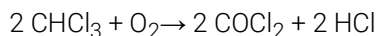

This reaction, in which stainless steel probably acts as a catalyst, occurs quickly with dried chloroform if the drying process removes the stabilizing alcohol.

- Chromatographic grade ethers, which can contain peroxides (for example, THF, dioxane, diisopropylether). Such ethers should be filtered through dry aluminium oxide which adsorbs the peroxides.
- Solutions of organic acids (acetic acid, formic acid, and so on) in organic solvents. For example, a 1 % solution of acetic acid in methanol will attack steel.
- Solutions containing strong complexing agents (for example, EDTA, ethylene diamine tetra-acetic acid).
- Mixtures of carbon tetrachloride with isopropanol or THF.

Titanium (Ti)

Titanium is highly resistant to oxidizing acids (for example, nitric, perchloric and hypochlorous acid) over a wide range of concentrations and temperatures. This is due to a thin oxide layer on the surface, which is stabilized by oxidizing compounds. Non-oxidizing acids (for example, hydrochloric, sulfuric and phosphoric acid) can cause slight corrosion, which increases with acid concentration and temperature. For example, the corrosion rate with 3 % HCl (about pH 0.1) at room temperature is about 13 $\mu\text{m}/\text{year}$. At room temperature, titanium is resistant to concentrations of about 5 % sulfuric acid (about pH 0.3). Addition of nitric acid to hydrochloric or sulfuric acids significantly reduces corrosion rates. Titanium is sensitive to acidic metal chlorides like FeCl_3 or CuCl_2 . Titanium is subject to corrosion in anhydrous methanol, which can be avoided by adding a small amount of water (about 3 %). Slight corrosion is possible with ammonia > 10 %.

Diamond-Like Carbon (DLC)

Diamond-Like Carbon is inert to almost all common acids, bases and solvents. There are no documented incompatibilities for HPLC applications.

Fused silica and Quartz (SiO_2)

Fused silica is used in Max Light Cartridges. Quartz is used for classical flow cell windows. It is inert against all common solvents and acids except hydrofluoric acid and acidic solvents containing fluorides. It is corroded by strong bases and should not be used above pH 12 at room temperature. The corrosion of flow cell windows can negatively affect measurement results. For a pH greater than 12, the use of flow cells with sapphire windows is recommended.

Gold

Gold is inert to all common HPLC solvents, acids and bases within the specified pH range. It can be corroded by complexing cyanides and concentrated acids like aqua regia.

Zirconium Oxide (ZrO_2)

Zirconium Oxide is inert to almost all common acids, bases and solvents. There are no documented incompatibilities for HPLC applications.

Preparing the Module

Solvent Information

Platinum/Iridium

Platinum/Iridium is inert to almost all common acids, bases and solvents. There are no documented incompatibilities for HPLC applications.

Fluorinated polymers (PTFE, PFA, FEP, FFKM, PVDF)

Fluorinated polymers like PTFE (polytetrafluorethylene), PFA (perfluoroalkoxy), and FEP (fluorinated ethylene propylene) are inert to almost all common acids, bases, and solvents. FFKM is perfluorinated rubber, which is also resistant to most chemicals. As an elastomer, it may swell in some organic solvents like halogenated hydrocarbons.

TFE/PDD copolymer tubings, which are used in all Agilent degassers except 1322A/G7122A, are not compatible with fluorinated solvents like Freon, Fluorinert, or Vertrel. They have limited life time in the presence of hexafluoroisopropanol (HFIP). To ensure the longest possible life with HFIP, it is best to dedicate a particular chamber to this solvent, not to switch solvents, and not to let dry out the chamber. For optimizing the life of the pressure sensor, do not leave HFIP in the chamber when the unit is off.

The tubing of the leak sensor is made of PVDF (polyvinylidene fluoride), which is incompatible with the solvent DMF (dimethyl formamide).

Sapphire, Ruby and Al₂O₃-based ceramics

Sapphire, ruby and ceramics based on aluminum oxide Al₂O₃ are inert to almost all common acids, bases and solvents. There are no documented incompatibilities for HPLC applications.

Capillary Coding Guide

Syntax for Capillary Description

The tables below are your guide to identifying the proper specifications for your capillary. On all capillaries, dimensions are noted in id (mm), length (mm) and, where applicable, volume (μL). When you receive your capillary, these abbreviations are printed on the packaging.

Using the guide: This fitting is coded as *SPF*, for Swagelok, PEEK, Fingertight.

Table 10 Capillary coding guide

Type The type gives some indication on the primary function, like a loop or a connection capillary.		Material The material indicates which raw material is used.		Fitting left/fitting right The fitting left/right indicate which fitting is used on both ends of the capillary.	
Key	Description	Key	Description	Key	Description
Capillary	Connection capillaries	SS	Stainless steel	W	Swagelok + 0.8 mm Port id
Loop	Loop capillaries	Ti	Titanium	S	Swagelok + 1.6 mm Port id
Seat	Autosampler needle seats	PK	PEEK	M	Metric M4 + 0.8 mm Port id
Tube	Tubing	FS/PK	PEEK-coated fused silica ¹	E	Metric M3 + 1.6 mm Port id
Heat exchanger	Heat exchanger	PK/SS	Stainless steel-coated PEEK ²	U	Swagelok union

Table 10 Capillary coding guide

Type The type gives some indication on the primary function, like a loop or a connection capillary.		Material The material indicates which raw material is used.		Fitting left/fitting right The fitting left/right indicate which fitting is used on both ends of the capillary.	
Key	Description	Key	Description	Key	Description
		PFFE	PTFE	L	Long
		FS	Fused silica	X	Extra long
		MP35N	Nickel-cobalt-chromium-molybdenum alloy	H	Long head
				G	Small head SW 4
				N	Small head SW 5
				F	Finger-tight
				V	1200 bar
				B	Bio
				P	PEEK
				I	Intermediate

¹ Fused silica in contact with solvent

² Stainless steel-coated PEEK

At-a-Glance Color-Coding Keys

The color of your capillary will help you quickly identify the capillary id.

Table 11 Color-coding key for Agilent capillary tubing

Internal diameter in mm		Color code
0.015		 Orange
0.025		 Yellow
0.05		 Beige
0.075		 Black
0.075	MP35N	 Black with orange stripe
0.1		 Purple
0.12		 Red
0.12	MP35N	 Red with orange stripe
0.17		 Green
0.17	MP35N	 Green with orange stripe
0.20/0.25		 Blue
0.20/0.25	MP35N	 Blue with orange stripe
0.3		 Grey
0.50		Bone White

HINT

As you move to smaller-volume, high efficiency columns, you'll want to use narrow id tubing, as opposed to the wider id tubing used for conventional HPLC instruments

Installing Capillaries

Capillaries and connections depend on which system is installed.

Table 12 Capillary connections for 1260 Infinity II systems

p/n	From	To
Bottle Head Assembly (G7120-60007)	Solvent Bottle	Infinity II Pump
Capillary ST 0.17 mm x 500 mm SI/SI (5500-1246)	Pump	Sampler
Capillary, ST, 0.17 mm x 900 mm SI/SX (5500-1217)	Pump	Vialsampler with ICC
Capillary ST 0.17 mm x 500 mm SI/SI (5500-1246)	Multisampler	MCT Valve/Heat Exchanger
Capillary, ST, 0.17 mm x 400 mm SL/SL (5500-1252)	Vialsampler	MCT Valve/Heat Exchanger
Capillary ST 0.17 mm x 105 mm SL/SL (5500-1240)	Vialsampler	ICC Heat Exchanger
Capillary, ST, 0.17 mm x 120 mm SL/SL, long socket (5500-1250)	ICC Heat Exchanger	Column
InfinityLab Quick Turn Capillary ST 0.17 mm x 105 mm, long socket (5500-1193)	MCT Heat Exchanger	Column
InfinityLab Quick Turn Capillary ST 0.12 mm x 280 mm, long socket (5500-1191)	Column/MCT Valve	Detector
Waste accessory kit (5062-8535)	VWD	Waste
Tube PTFE 0.7 mm x 5 m, 1.6 mm od (5062-2462)	DAD/FLD	Waste
Analytical tubing kit 0.25 mm i.d. PTFE-ESD (G5664-68712)	Detector	Fraction Collector

Table 13 Capillary connections for 1290 Infinity II systems

p/n	From	To
Bottle Head Assembly (G7120-60007)	Solvent Bottle	Infinity II Pump
Capillary ST 0.17 mm x 400 mm SI/SI (5500-1245)	Pump	Sampler
Capillary, ST, 0.17 mm x 900 mm SI/SX (5500-1217)	Pump	Vialsampler with ICC
Capillary ST, 0.12 mm x 500 mm SL/S (5500-1157)	Multisampler	MCT Valve/Heat Exchanger
Capillary ST 0.12 mmX 400 mm SL/SL (5500-1251)	Vialsampler	MCT Valve/Heat Exchanger
Capillary ST 0.12 mm x 105 mm SL/SL (5500-1238)	Vialsampler	ICC Heat Exchanger
Capillary ST 0.12 mm x 120 mm SL/SL, long socket (5500-1249)	ICC Heat Exchanger	Column
Capillary ST 0.12 mm x 105 mm SL/ (5500-1201)	MCT Heat Exchanger	Column
InfinityLab Quick Turn Capillary ST 0.12 mm x 280 mm, long socket (5500-1191)	Column/MCT Valve	Detector
Waste accessory kit (5062-8535)	VWD	Waste
Tube PTFE 0.7 mm x 5 m, 1.6 mm od (5062-2462)	DAD/FLD	Waste
Analytical tubing kit 0.25 mm i.d. PTFE-ESD (G5664-68712)	Detector	Fraction Collector

Table 14 Capillary connections for 1260 Infinity II Bio-inert LC

p/n	From	To
Bottle Head Assembly (G7120-60007)	Solvent Bottle	Infinity II Pump
Capillary Ti 0.17 mm x 500 mm, SL/SLV (5500-1264)	Pump	Multisampler
Capillary PK/ST 0.17 mm x 500 mm, RLO/RLO (Bio-inert) (G5667-81005)	Multisampler	MCT
ZDV union (Bio-inert) (5067-4741)	Capillary	Bio-inert Heat Exchanger
Quick Connect Heat Exchanger Bio-inert (G7116-60041)		
Capillary Kit Flow Cells BIO includes Capillary PK 0.18 mm x 1.5 m and PEEK Fittings 10/PK (p/n 5063-6591) (G5615-68755)	Column/MCT Valve	Detector
Waste accessory kit (5062-8535)	VWD	Waste
Tube PTFE 0.7 mm x 5 m, 1.6 mm od (5062-2462)	DAD/FLD	Waste
Analytical tubing kit 0.25 mm i.d. PTFE-ESD (G5664-68712)	Detector	Fraction Collector

Table 15 Capillary connections for 1290 Infinity II Bio LC

p/n	From	To
Bottle Head Assembly (G7120-60007)	Solvent Bottle	Infinity II Pump
Capillary MP35N 0.17 mm x 500 mm, SI/SI (5500-1419)	Pump	Multisampler
Capillary MP35N 0.12 mm x 500 mm SI/SI (5500-1279)	Multisampler	MCT
Quick Connect Capillary MP35N 0.12 mm x 105 mm (5500-1578)	MCT Heat Exchanger	Column
Quick Turn Capillary MP35N 0.12 mm x 280 mm (5500-1596)	Column/MCT Valve	Detector
Waste accessory kit (5062-8535)	VWD	Waste
Tube PTFE 0.7 mm x 5 m, 1.6 mm od (5062-2462)	DAD/FLD	Waste
Analytical tubing kit 0.25 mm i.d. PTFE-ESD (G5664-68712)	Detector	Fraction Collector

For correct installation of capillary connections it's important to choose the correct fittings, see [“Syntax for Capillary Description”](#) on page 69.

Preparing the Module Installing Capillaries

- 1 Select a nut that is long enough for the fitting you'll be using.



- 2 Slide the nut over the end of the tubing or capillary.

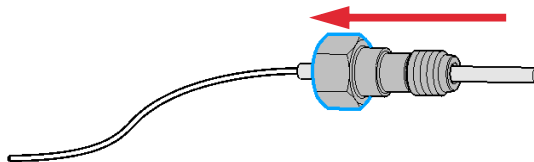

- 3 Carefully slide the ferrule components on after the nut and then finger-tighten the assembly while ensuring that the tubing is completely seated in the bottom of the end fitting.

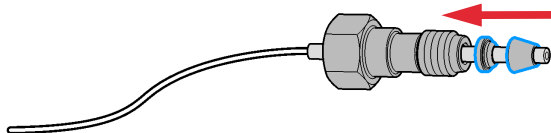

- 4 Use a column or injection valve to gently tighten the fitting which forces the ferrule to seat onto the tubing or capillary.

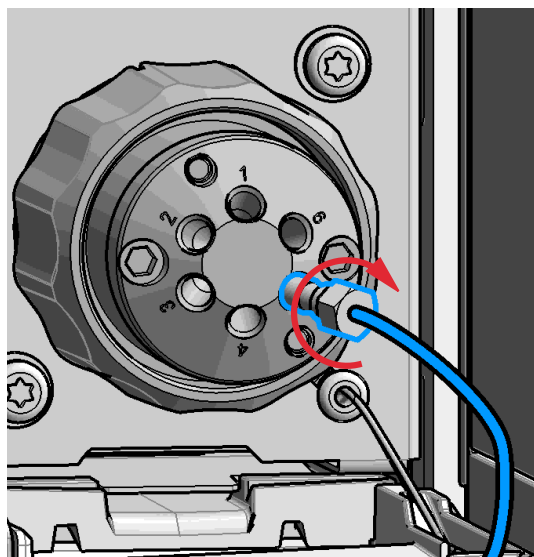

NOTE

Don't overtighten. Overtightening will shorten the lifetime of the fitting.

- 5 Loosen the nut and verify that the ferrule is correctly positioned on the tubing or capillary.

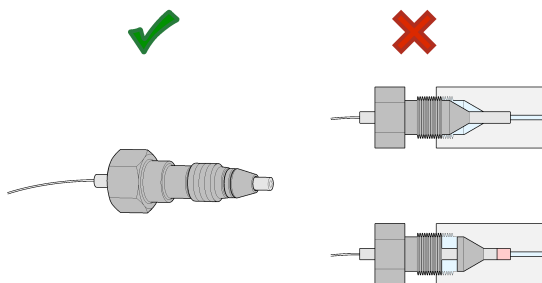

NOTE

The first time that the swagelock fitting is used on a column or an injection valve, the position of the ferrule is permanently set. If changing from a column or an injection valve to another, the fitting may leak or decrease the quality of the separation by contributing to band broadening.



5 Optimizing the Detector

Introduction	78
Match the Flow Cell to the Column	79
Set the Detector Parameters	82
Warm up of the Detector	83

This chapter provides information on how to optimize the detector.

Introduction

The detector has a variety of parameters that can be used to optimize performance.

The information below will guide you on how to get the best detector performance. Follow these rules as a start for new applications. It gives a rule-of-thumb for optimizing the detector parameters.

Match the Flow Cell to the Column

The tables below recommend the flow cell that matches the column used. If more than one selection is appropriate, use the larger flow cell to get the best detection limit. Use the smaller flow cell for best peak resolution.

Standard HPLC Applications

Column length	Typical peak width	Recommended flow cell					
<= 5 cm	0.025 min	Micro flow cell	Semimicro flow cell		Standard flow cell		High Pressure flow cell
10 cm	0.05 min						
20 cm	0.1 min						
>= 40 cm	0.2 min						
	Typical flow rate	0.05-0.2 ml/min	0.2- 0.4 ml/min	0.4- 0.8 ml/min	1-2 ml/min	0.01- 5 ml/min	
	Internal column diameter	1.0 mm	2.1mm	3.0 mm	4.6 mm		

Figure 19 Choosing a Flow Cell (Standard HPLC Applications)

Ultra fast separation with RRLC systems

Column ID	2.1 mm	3.0 mm	4.6 mm
Configuration	No damper No mixer ++	Damper Mixer	Damper Mixer
Flow cell	2 µl, 3 mm	5 µl, 6 mm +	14 µl, 10 mm +

Figure 20 Choosing a Flow Cell for G7114B (for ultra fast separation with RRLC systems)

- (+) For ultra fast analysis with step gradients the micro flow cell (2 µL, 3 mm) gives the best performance
- (++) In high resolution analysis time is not the highest priority. Higher delay volumes are accepted. Therefore we recommend to use the damper plus mixer for a highest signal to noise.
- If longer columns (> 50 mm) for higher resolution are used, then the next larger flow cell is the preferred choice for higher sensitivity.

Optimizing the Detector

Match the Flow Cell to the Column

Flow Cell Path Length

Lambert-Beer's law shows a linear relationship between the flow cell path length and absorbance.

$$\text{Absorbance} = -\log T = \log \frac{I_0}{I} = \epsilon \times C \times d$$

where

T	is the transmission, defined as the quotient of the intensity of the transmitted light I divided by the intensity of the incident light, I_0 ,
ϵ	is the extinction coefficient, which is a characteristic of a given substance under a precisely-defined set of conditions of wavelength, solvent, temperature and other parameters,
C [mol/L]	is the concentration of the absorbing species,
d [m]	is the path length of the cell used for the measurement.

Therefore, flow cells with longer path lengths yield higher signals. Although noise usually increases little with increasing path length, there is a gain in the signal-to-noise ratio. For example, in [Figure 21](#) on page 81 the noise increased by less than 10 % but a 70 % increase in signal intensity was achieved by increasing the path length from 6 mm to 10 mm.

When increasing the path length, the cell volume usually increases — in the example from 5 – 14 μL . Typically, this causes more peak dispersion. As demonstrated, this did not affect the resolution in the gradient separation in the example that is shown below.

As a rule-of-thumb, the flow cell volume should be about 1/3 of the peak volume at half height. To determine the volume of your peaks, take the peak width as reported in the integration results multiply it by the flow rate and divide it by 3).

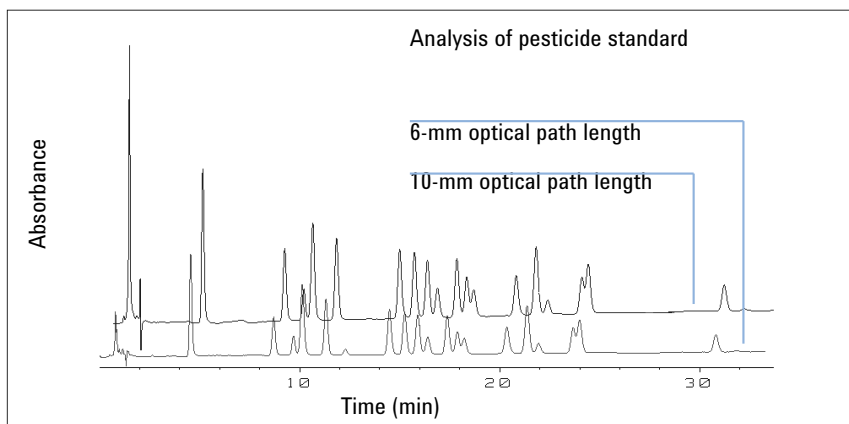

Figure 21 Influence of Cell Path Length on Signal Height

Traditionally LC analysis with UV detectors is based on comparing measurements with internal or external standards. To check photometric accuracy of the detector, it is necessary to have more precise information on path lengths of the flow cells.

The correct response is:

expected response * correction factor

Please find below the details of the flow cells:

Table 16 Correction factors for Agilent VWD flow cells

Part number	Path length (actual)	Correction factor
Standard flow cell 10 mm, 14 μ L, 40 bar (G1314-60186)	10.15 \pm 0.19 mm	10/10.15
Semi-micro flow cell 6 mm, 5 μ L (G1314-60183)	6.10 \pm 0.19 mm	6/6.10
Micro flow cell 3 mm, 2 μ L, 120 bar (G1314-60187)	2.80 \pm 0.19 mm	3/2.8
High pressure flow cell 10 mm, 14 μ L, 400 bar (G1314-60182)	10.00 \pm 0.19 mm	10/10
Bio standard flow cell VWD, 10 mm 14 μ L, RFID (G1314-60188)	10.15 \pm 0.19 mm	10/10.15
Bio micro flow cell VWD, 3 mm, 2 μ L, RFID (G1314-60189)	2.80 \pm 0.19 mm	3/2.8

NOTE

However you have to be aware that there is additional tolerance of gasket thickness and its compression ratio which is supposed to be very small in comparison with the machining tolerance.

Set the Detector Parameters

- 1** Set peakwidth as close as possible to the width (at half height) of a narrow peak of interest.
- 2** Choose the sample wavelength.
 - at a longer wavelength than the cut-off wavelength of the mobile phase,
 - at a wavelength where the analytes have strong absorptivity if you want to get the lowest possible detection limit,
 - at a wavelength with moderate absorptivity if you work with high concentrations, and
 - preferably where the spectrum is flat for better linearity.
- 3** Consider to use time-programming to further optimization.

Warm up of the Detector

Give the optical unit enough time to warm-up and stabilize (> 60 minutes). The detector is temperature controlled. After turn-on of the detector, it goes through a cycle of different states:

- 0 to 0.5 minutes the heater control is OFF and the heater element runs at 0 % duty cycle.
- 0.5 to 1 minutes the heater control is OFF and the heater element runs at 66% duty cycle. This first minute is used as self-test of the heater functionality.
- 1 to 30 minutes the heater control is OFF and the heater element runs at 40% duty cycle.
- After 30 minutes the heater control is ON and is working with optimized parameters to get the optical unit into the optimal temperature window stabilized.

This cycle starts

- when the detector is turned off/on
- when the lamp is turned off/on

to ensure that the temperature control operates in a defined control range.

NOTE

The times to stabilize the baseline may vary from instrument to instrument and depends on the environment. The example below was done under stable environmental conditions.

The figures below show the first two hours of a detector warm-up phase. The lamp was turned on immediately after turn on of the detector.

Optimizing the Detector

Warm up of the Detector

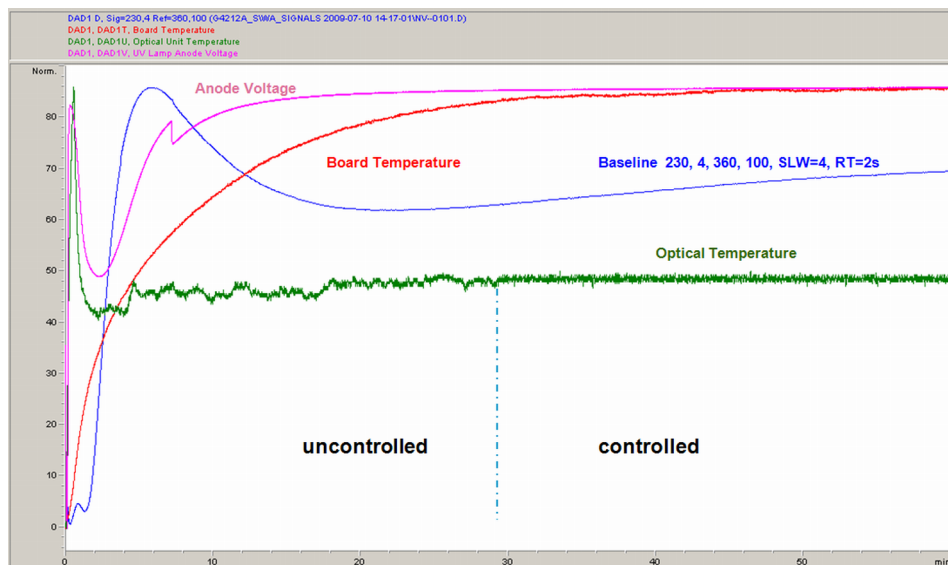

Figure 22 Detector Warm-up – 1st hour

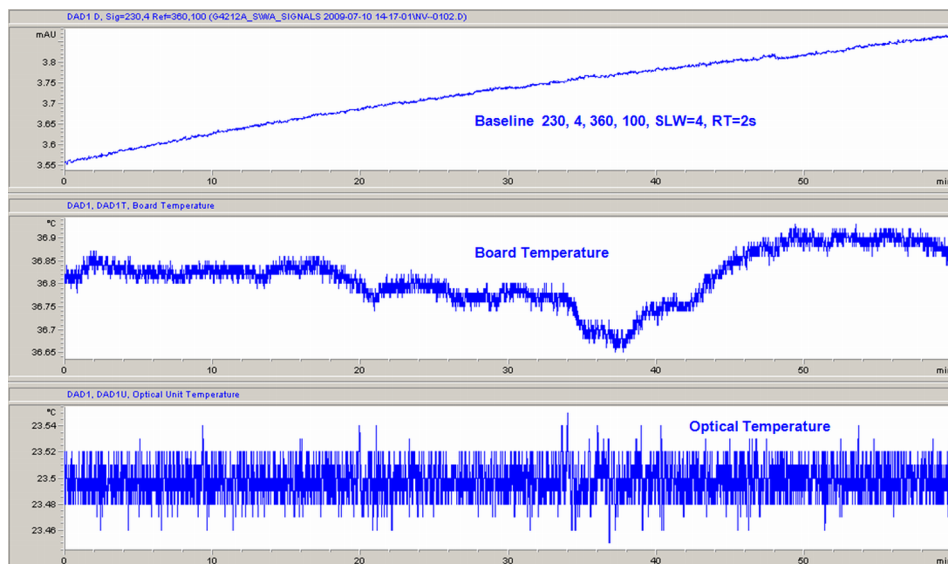

Figure 23 Detector Warm-up – 2nd hour



6 Troubleshooting and Diagnostics

Available Tests versus Interfaces 86

Agilent Lab Advisor Software 87

Overview about the troubleshooting and diagnostic features.

Available Tests versus Interfaces

NOTE

Depending on the used interface, the available tests and the screens/reports may vary.

Preferred tool should be the Agilent Lab Advisor, see “[Agilent Lab Advisor Software](#)” on page 87.

Agilent Lab Advisor B.02.08 or later is required.

The Instant Pilot (G4208A) supports the G7114B with B.02.19 and the G7114A with B.02.20 or later.

- Preferred tool should be the Agilent Lab Advisor software, see “[Agilent Lab Advisor Software](#)” on page 87
- Screenshots used within these procedures are based on the Agilent Lab Advisor software.

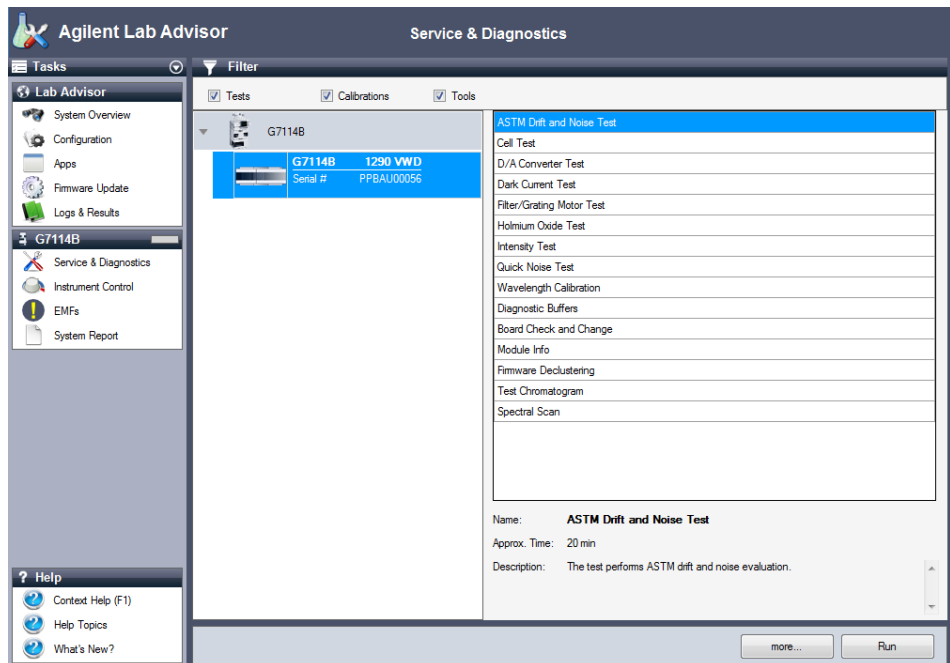

Figure 24 The Lab Advisor shows the available test

Agilent Lab Advisor Software

The Agilent Lab Advisor Software (basic license, shipped with an Agilent LC pump) is a standalone product that can be used with or without a chromatographic data system. Agilent Lab Advisor helps to manage the lab for high-quality chromatographic results by providing a detailed system overview of all connected analytical instruments with instrument status, Early Maintenance Feedback counters (EMF), instrument configuration information, and diagnostic tests. With the push of a button, a detailed diagnostic report can be generated. Upon request, the user can send this report to Agilent for a significantly improved troubleshooting and repair process.

The Agilent Lab Advisor software is available in two versions:

- Lab Advisor Basic
- Lab Advisor Advanced

Lab Advisor Basic is included with every Agilent 1200 Infinity Series and Agilent InfinityLab LC Series instrument.

The Lab Advisor Advanced features can be unlocked by purchasing a license key, and include real-time monitoring of instrument actuals, all various instrument signals, and state machines. In addition, all diagnostic test results, calibration results, and acquired signal data can be uploaded to a shared network folder. The Review Client included in Lab Advisor Advanced allows to load and examine the uploaded data no matter on which instrument it was generated. This makes Data Sharing an ideal tool for internal support groups and users who want to track the instrument history of their analytical systems.

The optional Agilent Maintenance Wizard Add-on provides an easy-to-use, step-by-step multimedia guide for performing preventive maintenance on Agilent 1200 Infinity LC Series instrument.

The tests and diagnostic features that are provided by the Agilent Lab Advisor software may differ from the descriptions in this manual. For details, refer to the Agilent Lab Advisor software help files.

7

Error Information

What Are Error Messages	89
General Error Messages	90
Timeout	90
Shutdown	91
Remote Timeout	92
Lost CAN Partner	92
Leak	93
Leak Sensor Open	93
Leak Sensor Short	94
Compensation Sensor Open	94
Compensation Sensor Short	95
Fan Failed	95
Open Cover	96
ERI Messages	96
Detector Error Messages	97
UV lamp: no current	97
UV lamp: no voltage	98
Ignition Failed	98
No heater current	99
Wavelength calibration setting failed	100
Wavelength holmium check failed	101
Grating or Filter Motor Errors	102
Wavelength test failed	102
Cutoff filter doesn't decrease the light intensity at 250 nm	103
ADC Hardware Error	103
Illegal Temperature Value from Sensor on Main Board	104
Illegal Temperature Value from Sensor at Air Inlet	104
Heater at fan assembly failed	105
Heater Power At Limit	105
Cover Violation	106

This chapter describes the meaning of detector error messages, and provides information on probable causes and suggested actions how to recover from error conditions.

What Are Error Messages

Error messages are displayed in the user interface when an electronic, mechanical, or hydraulic (flow path) failure occurs which requires attention before the analysis can be continued (for example, repair, or exchange of consumables is necessary). In the event of such a failure, the red status indicator at the front of the module is switched on, and an entry is written into the module logbook.

If an error occurs outside a method run, other modules will not be informed about this error. If it occurs within a method run, all connected modules will get a notification, all LEDs get red and the run will be stopped. Depending on the module type, this stop is implemented differently. For example, for a pump the flow will be stopped for safety reasons. For a detector, the lamp will stay on in order to avoid equilibration time. Depending on the error type, the next run can only be started, if the error has been resolved, for example liquid from a leak has been dried. Errors for presumably single time events can be recovered by switching on the system in the user interface.

Special handling is done in case of a leak. As a leak is a potential safety issue and may have occurred at a different module from where it has been observed, a leak always causes a shutdown of all modules, even outside a method run.

In all cases, error propagation is done via the CAN bus or via an APG/ERI remote cable (see documentation for the APG/ERI interface).

General Error Messages

General error messages are generic to all Agilent series HPLC modules and may show up on other modules as well.

Timeout

Error ID: 0062

The timeout threshold was exceeded.

Probable cause	Suggested actions
1 The analysis was completed successfully, and the timeout function switched off the module as requested.	Check the logbook for the occurrence and source of a not-ready condition. Restart the analysis where required.
2 A not-ready condition was present during a sequence or multiple-injection run for a period longer than the timeout threshold.	Check the logbook for the occurrence and source of a not-ready condition. Restart the analysis where required.

Shutdown

Error ID: 0063

An external instrument has generated a shutdown signal on the remote line.

The module continually monitors the remote input connectors for status signals. A LOW signal input on pin 4 of the remote connector generates the error message.

Probable cause	Suggested actions
1 Leak detected in another module with a CAN connection to the system.	Fix the leak in the external instrument before restarting the module.
2 Leak detected in an external instrument with a remote connection to the system.	Fix the leak in the external instrument before restarting the module.
3 Shut-down in an external instrument with a remote connection to the system.	Check external instruments for a shut-down condition.
4 The degasser failed to generate sufficient vacuum for solvent degassing.	Check the vacuum degasser for an error condition. Refer to the <i>Service Manual</i> for the degasser or the pump that has the degasser built-in.

Remote Timeout

Error ID: 0070

A not-ready condition is still present on the remote input. When an analysis is started, the system expects all not-ready conditions (for example, a not-ready condition during detector balance) to switch to run conditions within one minute of starting the analysis. If a not-ready condition is still present on the remote line after one minute the error message is generated.

Probable cause	Suggested actions
1 Not-ready condition in one of the instruments connected to the remote line.	Ensure the instrument showing the not-ready condition is installed correctly, and is set up correctly for analysis.
2 Defective remote cable.	Exchange the remote cable.
3 Defective components in the instrument showing the not-ready condition.	Check the instrument for defects (refer to the instrument's documentation).

Lost CAN Partner

Error ID: 0071

During an analysis, the internal synchronization or communication between one or more of the modules in the system has failed.

The system processors continually monitor the system configuration. If one or more of the modules is no longer recognized as being connected to the system, the error message is generated.

Probable cause	Suggested actions
1 CAN cable disconnected.	<ul style="list-style-type: none"> Ensure all the CAN cables are connected correctly. Ensure all CAN cables are installed correctly.
2 Defective CAN cable.	Exchange the CAN cable.
3 Defective mainboard in another module.	Switch off the system. Restart the system, and determine which module or modules are not recognized by the system.

Leak

Error ID: 0064

A leak was detected in the module.

The signals from the two temperature sensors (leak sensor and board-mounted temperature-compensation sensor) are used by the leak algorithm to determine whether a leak is present. When a leak occurs, the leak sensor is cooled by the solvent. This changes the resistance of the leak sensor which is sensed by the leak sensor circuit on the main board.

Probable cause	Suggested actions
1 Loose fittings.	Ensure all fittings are tight.
2 Broken capillary.	Exchange defective capillaries.
3 Leaking flow cell.	Exchange flow cell components.

Leak Sensor Open

Error ID: 0083

The leak sensor in the module has failed (open circuit).

The current through the leak sensor is dependent on temperature. A leak is detected when solvent cools the leak sensor, causing the leak sensor current to change within defined limits. If the current falls outside the lower limit, the error message is generated.

Probable cause	Suggested actions
1 Leak sensor not connected to the power switch board.	Please contact your Agilent service representative.
2 Defective leak sensor.	Please contact your Agilent service representative.
3 Leak sensor incorrectly routed, being pinched by a metal component.	Please contact your Agilent service representative.
4 Power switch assembly defective	Please contact your Agilent service representative.

Leak Sensor Short

Error ID: 0082

The leak sensor in the module has failed (short circuit).

The current through the leak sensor is dependent on temperature. A leak is detected when solvent cools the leak sensor, causing the leak sensor current to change within defined limits. If the current increases above the upper limit, the error message is generated.

Probable cause	Suggested actions
1 Defective leak sensor.	Please contact your Agilent service representative.
2 Leak sensor incorrectly routed, being pinched by a metal component.	Please contact your Agilent service representative.
3 Power switch assembly defective	Please contact your Agilent service representative.
4 Cable or contact problem.	Please contact your Agilent service representative.

Compensation Sensor Open

Error ID: 0081

The ambient-compensation sensor (NTC) on the power switch board in the module has failed (open circuit).

The resistance across the temperature compensation sensor (NTC) on the power switch board is dependent on ambient temperature. The change in resistance is used by the leak circuit to compensate for ambient temperature changes. If the resistance across the sensor increases above the upper limit, the error message is generated.

Probable cause	Suggested actions
1 Loose connection between the power switch board and the mainboard	Please contact your Agilent service representative.
2 Defective power switch assembly	Please contact your Agilent service representative.

Compensation Sensor Short

Error ID: 0080

The ambient-compensation sensor (NTC) on the power switch board in the module has failed (open circuit).

The resistance across the temperature compensation sensor (NTC) on the power switch board is dependent on ambient temperature. The change in resistance is used by the leak circuit to compensate for ambient temperature changes. If the resistance across the sensor falls below the lower limit, the error message is generated.

Probable cause	Suggested actions
1 Defective power switch assembly	Please contact your Agilent service representative.
2 Loose connection between the power switch board and the mainboard	Please contact your Agilent service representative.

Fan Failed

Error ID: 0068

The cooling fan in the module has failed.

The hall sensor on the fan shaft is used by the mainboard to monitor the fan speed. If the fan speed falls below a certain limit for a certain length of time, the error message is generated.

This limit is given by 2 revolutions/second for longer than 5 seconds.

Depending on the module, assemblies (e.g. the lamp in the detector) are turned off to assure that the module does not overheat inside.

Probable cause	Suggested actions
1 Fan cable disconnected.	Please contact your Agilent service representative.
2 Defective fan.	Please contact your Agilent service representative.
3 Defective mainboard.	Please contact your Agilent service representative.

Open Cover

Error ID: 0205

The top foam has been removed.

The sensor on the main board detects when the top foam is in place. If the foam is removed, the fan is switched off, and the error message is generated.

Probable cause	Suggested actions
1 The top foam was removed during operation.	Please contact your Agilent service representative.
2 Foam not activating the sensor.	Please contact your Agilent service representative.
3 Defective sensor or main board.	Please contact your Agilent service representative.

ERI Messages

Error ID: 11120 (+5 V) , 11121 (+25 V)

The ERI (Enhanced Remote Interface) provides two error events related to over current situations on the +5 V and +24 V lines.

Probable cause	Suggested actions
1 The load on the ERI is too high.	Reduce the load.

Detector Error Messages

These errors are detector specific.

UV lamp: no current

Error ID: 7450

The lamp anode current is missing. The processor continually monitors the anode current drawn by the lamp during operation. If the anode current falls below the lower current limit, the error message is generated.

Probable cause	Suggested actions
1 Lamp disconnected.	Ensure the lamp connector is seated firmly.
2 Top foam removed while lamp is on.	Please contact your Agilent service representative.
3 Defective or non-Agilent lamp.	Exchange the lamp.
4 Defective mainboard.	Please contact your Agilent service representative.
5 Defective power supply.	Please contact your Agilent service representative.

UV lamp: no voltage

Error ID: 7451

The lamp anode voltage is missing. The processor continually monitors the anode voltage across the lamp during operation. If the anode voltage falls below the lower limit, the error message is generated.

Probable cause	Suggested actions
1 Defective or non-Agilent lamp.	Exchange the lamp.
2 Defective power supply.	Please contact your Agilent service representative.
3 Defective mainboard.	Please contact your Agilent service representative.

Ignition Failed

Error ID: 7452

The lamp failed to ignite. The processor monitors the lamp current during the ignition cycle. If the lamp current does not rise above the lower limit within 2 – 5 s, the error message is generated.

Probable cause	Suggested actions
1 Lamp disconnected.	Ensure the lamp is connected.
2 Defective or non-Agilent lamp.	Exchange the lamp.
3 Defective power supply.	Please contact your Agilent service representative.
4 Defective mainboard.	Please contact your Agilent service representative.

No heater current

Error ID: 7453

The lamp heater current in the detector is missing. During lamp ignition, the processor monitors the heater current. If the current does not rise above the lower limit within 1, the error message is generated.

Probable cause	Suggested actions
1 Lamp disconnected.	Ensure the lamp is connected.
2 Ignition started without the top foam in place.	Please contact your Agilent service representative.
3 Fan not running (permitting lamp on).	Please contact your Agilent service representative.
4 Defective mainboard.	Please contact your Agilent service representative.
5 Defective or non-Agilent lamp.	Exchange the lamp.
6 Defective power supply.	Please contact your Agilent service representative.

Wavelength calibration setting failed

Error ID: 7310

The intensity maximum was not found during wavelength calibration.

Calibration 0 Failed: Zero-order calibration failed.

Calibration 1 Failed: 656 nm calibration failed.

Probable cause	Suggested actions
1 Lamp is OFF.	Switch on the lamp.
2 Incorrect flow cell installation.	Ensure the flow cell is installed correctly.
3 Flow cell contamination or air bubbles.	Clean/replace flow cell windows or remove air bubbles.
4 Intensity too low.	Replace lamp.
5 Current step value too far from maximum.	<ul style="list-style-type: none">• Repeat the calibration.• Please contact your Agilent service representative.
6 Misaligned/defective grating assembly.	Please contact your Agilent service representative.
7 Defective mainboard.	Please contact your Agilent service representative.

Wavelength holmium check failed

Error ID: 7318

The holmium oxide test in the detector has failed. During the holmium test, the detector moves the holmium filter into the light path, and compares the measured absorbance maxima of the holmium oxide filter with expected maxima. If the measured maxima are outside the limits, the error message is generated.

Probable cause	Suggested actions
1 Misaligned/defective grating assembly.	<ul style="list-style-type: none">• Ensure the flow cell is inserted correctly, and is free from contamination (cell windows, buffers, and so on).• Run the filter-motor test to determine if the filter motor assembly is defective. If defective, please contact your Agilent service representative.• Run the grating-motor test to determine if the grating assembly is defective. If defective, please contact your Agilent service representative.

Grating or Filter Motor Errors

Error ID: Grating: 7800, 7801, 7802, 7803, 7804, 7805, 7806, 7808, 7809; Filter: 7810, 7811, 7812, 7813, 7814, 7815, 7816

The motor test has failed.

Test 0 Failed:	Filter motor.
Test 1 Failed:	Grating motor.

During the motor tests, the detector moves the motor to the end position while monitoring the end-position sensor. If the end position is not found, the error message is generated.

Probable cause	Suggested actions
1 Motor is not connected.	Please contact your Agilent service representative.
2 Defective motor.	Please contact your Agilent service representative.
3 Defective/missing grating or filter.	Please contact your Agilent service representative.
4 Cable/connector defective.	Please contact your Agilent service representative.

Wavelength test failed

Error ID: 7890

The automatic wavelength check after lamp ignition has failed. When the lamp is switched on, the detector waits 1 min to warm-up the lamp. Then a check of the deuterium emission line (656 nm) via the reference diode is performed. If the emission line is more than 3 nm away from 656 nm, the error message is generated.

Probable cause	Suggested actions
1 Calibration incorrect.	Recalibrate the detector.

Cutoff filter doesn't decrease the light intensity at 250 nm

Error ID: 7813

The automatic filter check after lamp ignition has failed. When the lamp is switched on, the detector moves the cutoff filter into the light path. If the filter is functioning correctly, a decrease in lamp intensity is seen. If the expected intensity decrease is not detected, the error message is generated.

Probable cause	Suggested actions
1 Motor is not connected.	Please contact your Agilent service representative.
2 Defective motor.	Please contact your Agilent service representative.
3 Defective/missing grating or filter.	Please contact your Agilent service representative.
4 Cable/connector defective.	Please contact your Agilent service representative.

ADC Hardware Error

Error ID: 7830, 7831

A/D-Converter hardware is defective.

Probable cause	Suggested actions
1 A/D-Converter hardware is defective.	Please contact your Agilent service representative.

Illegal Temperature Value from Sensor on Main Board

Error ID: 1071

This temperature sensor (located on the detector main board) delivered a value outside the allowed range. The parameter of this event equals the measured temperature in 1/100 centigrade. As a result the temperature control is switched off.

Probable cause	Suggested actions
1 Defective sensor or main board.	Please contact your Agilent service representative.
2 Detector is exposed to illegal ambient conditions.	Verify that the ambient conditions are within the allowed range.

Illegal Temperature Value from Sensor at Air Inlet

Error ID: 1072

This temperature sensor delivered a value outside the allowed range. The parameter of this event equals the measured temperature in 1/100 centigrade. As a result the temperature control is switched off.

Probable cause	Suggested actions
1 The temperature sensor is defect.	<ul style="list-style-type: none"> Replace the cable to the main board. Please contact your Agilent service representative.
2 Detector is exposed to illegal ambient conditions.	Verify that the ambient conditions are within the allowed range.

Heater at fan assembly failed

Error ID: 1073

Every time the deuterium lamp or the tungsten lamp (DAD only) is switched on or off a heater self-test is performed. If the test fails an error event is created. As a result the temperature control is switched off.

Probable cause	Suggested actions
1 Defective connector or cable.	Please contact your Agilent service representative.
2 Defective heater.	Please contact your Agilent service representative.

Heater Power At Limit

Error ID: 1074

The available power of the heater reached either the upper or lower limit. This event is sent only once per run. The parameter determines which limit has been hit:

0 means upper power limit hit (excessive ambient temperature drop).

1 means lower power limit hit (excessive ambient temperature increase).

Probable cause	Suggested actions
1 Excessive ambient temperature change.	Wait until temperature control equilibrates.

Cover Violation

Error ID: 7461

The top foam has been removed.

The sensor on the main board detects when the top foam is in place. If the foam is removed while the lamps are on (or if an attempt is made to switch on for example the lamps with the foam removed), the lamps are switched off, and the error message is generated.

Probable cause	Suggested actions
1 The top foam was removed during operation.	Please contact your Agilent service representative.
2 Foam not activating the sensor.	Please contact your Agilent service representative.

8 Test Functions

Introduction	108
Intensity Test	113
Intensity Test Evaluation	114
Intensity Test Failed	115
Cell Test	116
Cell Test Failed	117
Wavelength Verification-Calibration	118
When to Calibrate the Detector	118
ASTM Drift and Noise Test	120
Quick Noise Test	121
Dark Current Test	123
Dark Current Test Failed	124
Holmium Oxide Test	125
When to do the Test	125
Interpreting the Results	126
Holmium Oxide Test Failed	127
D/A Converter (DAC) Test	128
D/A Converter Test Evaluation	130
Other Lab Advisor Functions	131
EMFs - Early Maintenance Feature	131

This chapter describes the detector's built in test functions.

Introduction

All tests are described based on the Agilent Lab Advisor Software B.02.08. Other user interfaces may not provide any test or just a few.

Table 17 Interfaces and available test functions

Interface	Comment	Available Function
Agilent Lab Advisor	For functions, refer to Function Overview Lab Advisor <ul style="list-style-type: none"> • G7114A/B(Table 18 on page 109) 	Available functions depend on Product Level (Basic – Advanced – FSE)
Agilent ChemStation	No tests available Adding of temperature/lamp signals to chromatographic signals possible	<ul style="list-style-type: none"> • Temperature main board • Temperature optical unit • Lamp anode voltage

Table 18 Function Overview Lab Advisor Basic/Advanced (G7114A/G7114B)

Function	Product Level	
Tests		
- ASTM Drift and Noise Test	Basic	Advanced
- Cell Test	Basic	Advanced
- D/A Converter Test	Basic	Advanced
- Dark Current Test	Basic	Advanced
- Filter/Grating Motor Test	Basic	Advanced
- Holmium Oxide Test	Basic	Advanced
- Intensity Test	Basic	Advanced
- Quick Noise Test	Basic	Advanced
Calibrations		
- Wavelength Calibration	Basic	Advanced
Tools		
- Diagnostic Buffers	Basic	Advanced
- Board Check and Change		
- Module Info	Basic	Advanced
- Firmware Declustering		
- Test Chromatogram	Basic	Advanced
- Spectral Scan	Basic	Advanced
Controls		
- Advanced Method Parameters		
- Analog Output 1 Attenuation		Advanced
- D2 lamp required		Advanced
- Analog Output 1 Off-set [% Full Scale]		Advanced

Table 18 Function Overview Lab Advisor Basic/Advanced (G7114A/G7114B)

Function	Product Level	
- Configuration		
- Remote Pulse Duration [s] *	Basic	Advanced
- Analog Output 1 Range		Advanced
- Control		
- Balance Detector		Advanced
- UV Lamp	Basic	Advanced
- Conversions		
- Transfer to Resident FW		
- Transfer to Main FW *		
- G7114B allows G1314E and G1314F	Basic	Advanced
- G7114A allows NONE	Basic	Advanced
- Method Parameters		
- Set Data Rate [Hz]		Advanced
- Set Wavelength [nm]		Advanced
- Module Information		
- Firmware Version		
- Identify Module	Basic	Advanced
- Special Commands		
- Lamp tag required	Basic	Advanced
- Cell tag required	Basic	Advanced
- Clear Error	Basic	Advanced
- Detector Reset	Basic	Advanced
- Forced Cold Start		

Table 18 Function Overview Lab Advisor Basic/Advanced (G7114A/G7114B)

Function	Product Level	
Actuals		
- Signal A [mAU]		Advanced
- Sample Signal		
- Reference Signal		
Statemachines		
- UV Lamp	Basic	Advanced
Signals		
- Signal A [mAU]		Advanced
- Sample Signal [mAU]		Advanced
- Reference Signal [mAU]		Advanced
- Board Temperature [°C]		Advanced
- Lamp Voltage [V]		Advanced
EMF Counters		
- Accumulated UV Lamp On-Time	Basic	Advanced
- Number of UV Lamp Ignitions	Basic	Advanced

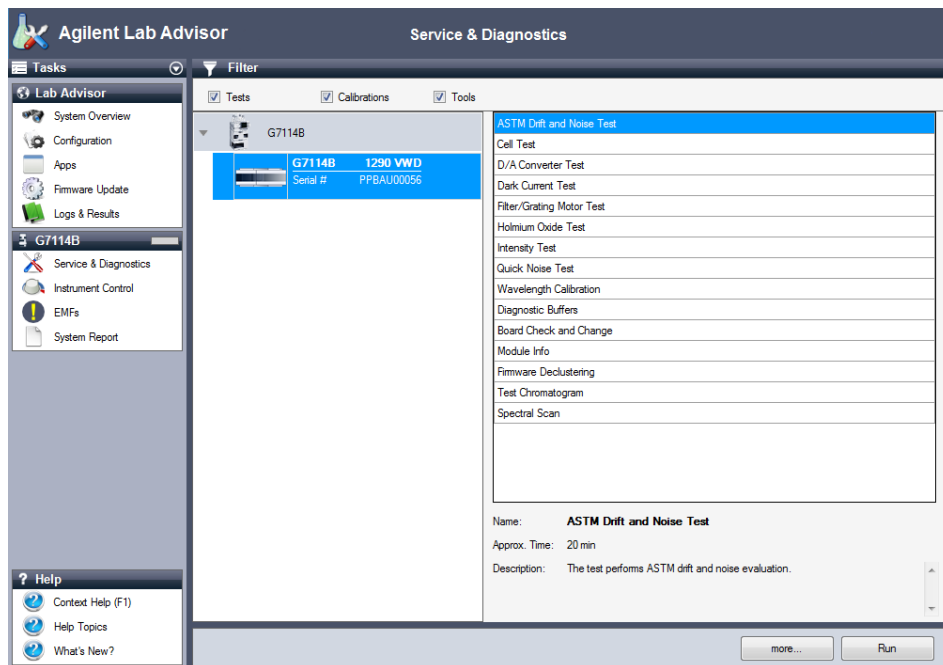

Figure 25 The Lab Advisor shows the available test

Intensity Test

The intensity test measures the intensity of the deuterium lamp over the full VWD wavelength range (190 - 600 nm). The test can be used to determine the performance of the lamp, and to check for dirty or contaminated flow cell windows. When the test is started, the gain is set to zero. To eliminate effects due to absorbing solvents, the test should be done with water in the flow cell. The shape of the intensity spectrum is primarily dependent on the lamp, grating, and diode characteristics. Therefore, intensity spectra will differ slightly between instruments. The figure below shows a typical intensity test spectrum.

The Intensity Test is available in Agilent Lab Advisor (preferred tool).

Intensity Test Evaluation

The Agilent Lab Advisor and the Instant Pilot evaluate three values automatically and display the limits for each value, the average, the minimum and the maximum of all data points and **passed** or **failed** for each value.

- 1 Run the Intensity-Test with Agilent Lab Advisor (for further information see Online-Help of user interface).

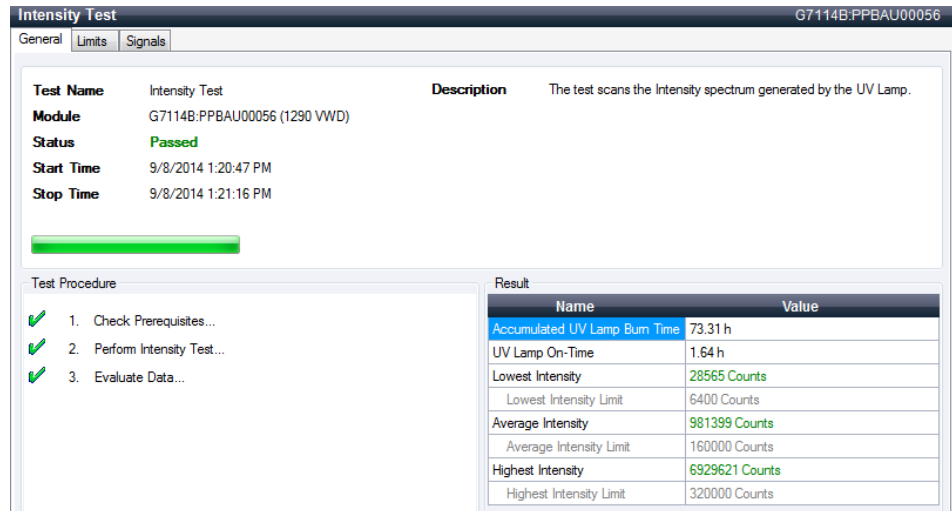

Figure 26 Intensity Test – Results

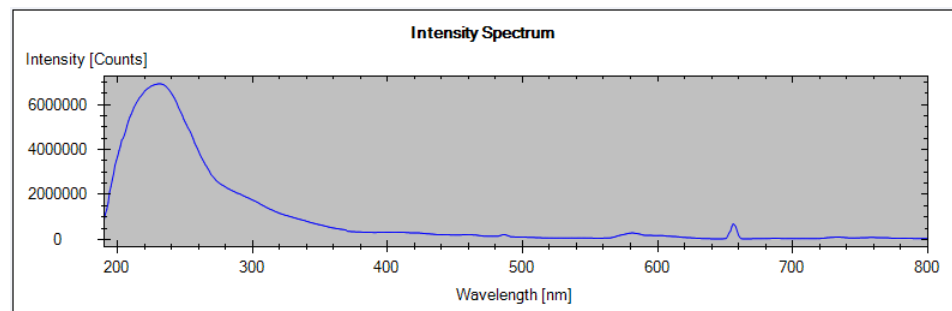

Figure 27 Intensity Test – Signal

Intensity Test Failed

Intensity Test Failed

Probable cause	Suggested actions
1 Empty flow cell	Ensure the flow cell is filled with water.
2 Flow cell windows dirty	Repeat the test with the flow cell window removed. If the test passes, exchange the flow cell windows.
3 Optics defect	Please contact your Agilent service representative.
4 Defective lamp or optics.	Exchange the lamp.

Cell Test

The cell test compares the intensity of the deuterium lamp measured by the sample and reference diodes (unfiltered and not logarithmized) when the grating is in the zero-order position. The resulting intensity ratio (sample:reference) is a measure of the amount of light absorbed by the flow cell.

The test can be used to check for dirty or contaminated flow cell windows. When the test is started, the gain is set to -1. To eliminate effects due to absorbing solvents, the test should be done with water in the flow cell.

Limits: No real limit. The reason is that it depends on the position/alignment of the reference side (beam splitter – reference slit – reference diode). Therefore the reference side value can be higher/smaller than the sample side value.

With a clean cell the counts for sample and reference (photocurrent) are in the same range. If the sample side shows much lower values than the reference side the flow cell might have a problem.

Prerequisites

Flush the flow cell with a flow of 1 mL/min for at least 10 minutes.

- 1 Run the Cell-Test with Agilent Lab Advisor (for further information see Online-Help of user interface).

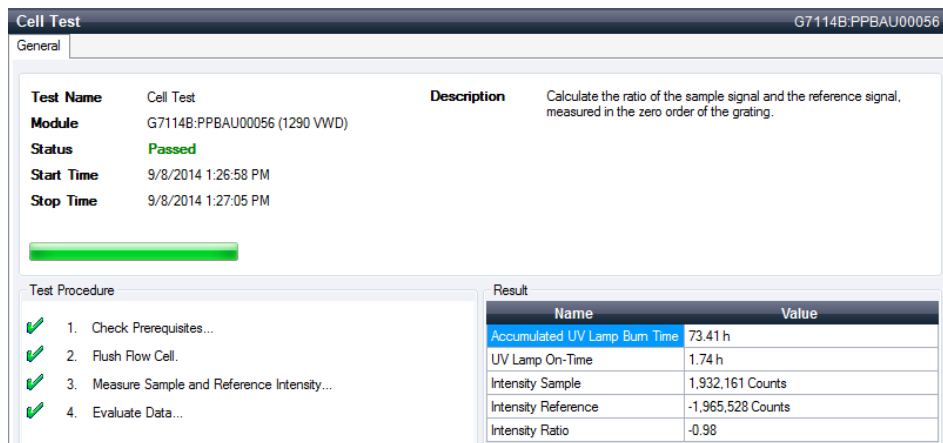

Name	Value
Accumulated UV Lamp Burn Time	73.41 h
UV Lamp On-Time	1.74 h
Intensity Sample	1,932,161 Counts
Intensity Reference	-1,965,528 Counts
Intensity Ratio	-0.98

Figure 28 Test – Results

Cell Test Failed

Cell Test Failed

Probable cause	Suggested actions
1 Cell contaminated	Flush flow cell
2 Cell windows are contaminated	Clean/replace cell windows
3 Mechanical problem	Check cell position

Wavelength Verification-Calibration

Wavelength calibration of the detector is done using the zero-order position and 656 nm emission line position of the deuterium lamp. The calibration procedure involves two steps. First the grating is calibrated on the zero-order position. The stepper-motor step position where the zero-order maximum is detected is stored in the detector. Next, the grating is calibrated against the deuterium emission-line at 656 nm, and the motor position at which the maximum occurs is stored in the detector.

In addition to the zero-order and 656 nm (alpha-emission line) calibration, the beta-emission line at 486 nm and the three holmium lines are used for the complete wavelength calibration process. These holmium lines are at 360.8 nm, 418.5 nm and 536.4 nm.

NOTE

The wavelength verification/calibration takes about 2.5 min and is disabled within the first 10 min after ignition of the lamp because initial drift may distort the measurement.

When the lamp is turned **ON**, the 656 nm emission line position of the deuterium lamp is checked automatically.

The Wavelength Verification/Calibration is available in Agilent Lab Advisor (preferred tool).

When to Calibrate the Detector

The detector is calibrated at the factory, and under normal operating conditions should not require recalibration. However, it is advisable to recalibrate:

- after maintenance (flow cell or lamp),
- after repair of components in the optical unit,
- after exchange of the optical unit or VWM board,
- at a regular interval, at least once per year (for example, prior to an Operational Qualification/Performance Verification procedure), and
- when chromatographic results indicate the detector may require recalibration.

NOTE

If the detector was repaired (opened covers), the wavelength calibration can be done 10 minutes after lamp on. A final wavelength calibration should be repeated after complete warm-up of the detector.

- 1 Run the Wavelength Calibration with the Agilent Lab Advisor (for further information see Online-Help of user interface).

The screenshot displays the 'Wavelength Calibration' software window. The main window has a 'General' tab and shows the following information:

- Test Name:** Wavelength Calibration
- Module:** G7114B:PPBAU00056
- Approx. Time:** 3 min
- Status:** Running

A progress bar is visible below the status. The 'Test Procedure' section lists three steps:

1. Check Prerequisites... (checked)
2. Wavelength Verification... (checked)
3. Calibrate Detector... (active)

The 'Result' section contains a table with the following data:

Name	Value
Accumulated UV Lamp Burn Time	73.95 h
UV Lamp On-Time	2.28 h
Time to Wait Before Wavelength Calibration Can Be Started	0.00 min
Time to Wait Before Wavelength Calibration Can Be Started	0 ... 0 min
Wavelength Deviation of 0-order Calibration	0.200 nm
Wavelength Deviation of alpha line Calibration	0.000 nm

A dialog box titled 'Wavelength Calibration' is overlaid on the main window, asking: 'Do you want to calibrate the detector using the wavelength verification results?'. It has 'Yes' and 'No' buttons.

Figure 29 Wavelength Calibration - Results

If you select **No**, the test is aborted.

If you select **Yes**, the re-calibration is performed (the offset is corrected).

ASTM Drift and Noise Test

The ASTM Drift and Noise test determines the detector noise over a period of 20 minutes. The test is done with HPLC-grade water flowing through the flow cell at 1 mL/min. On completion of the test, the noise result is displayed automatically.

- 1 Run the ASTM Drift and Noise Test with Agilent Lab Advisor (for further information see Online- Help of user interface).

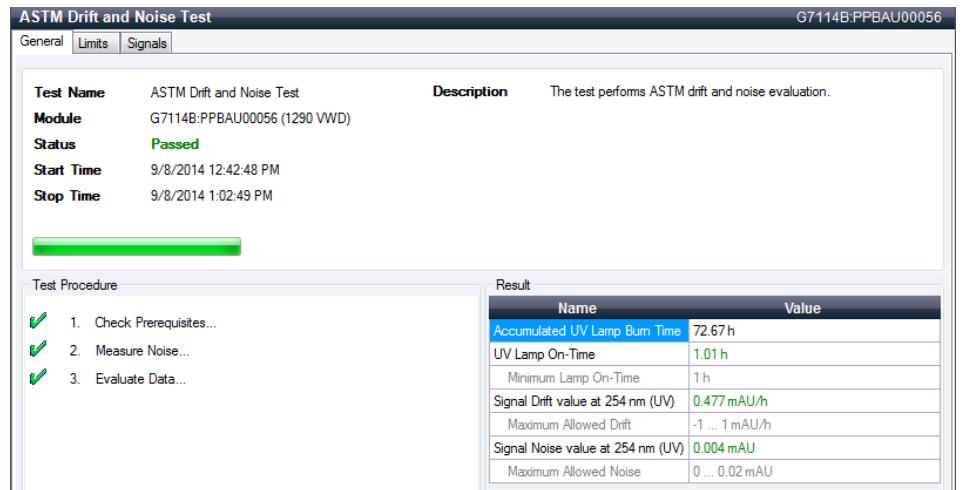

Figure 30 ASTM Drift and Noise Test – Results

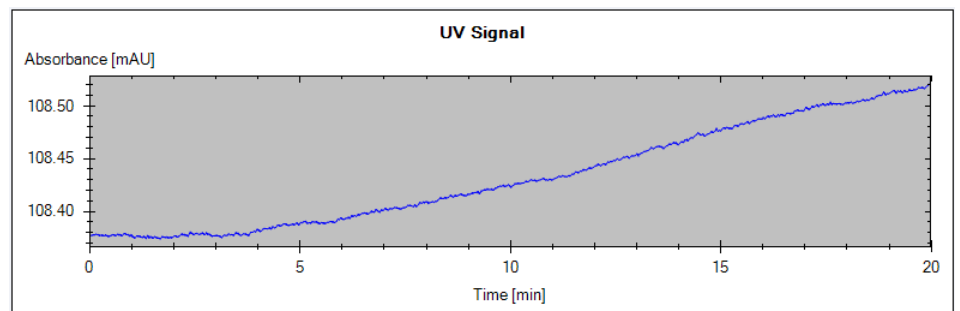

Figure 31 Drift and Noise Test – Signal

Quick Noise Test

The noise test measures the noise of the detector, with HPLC-grade water flowing through the flow cell at 1 mL/min, in one minute intervals over a total of 5 minutes.

The noise of the detector is calculated by using the maximum amplitude for all random variations of the detector signal of frequencies greater than one cycle per hour. The noise is determined for 5 one minute intervals and is based on the accumulated peak-to-peak noise for the intervals. At least seven data points per cycles are used in the calculation.

The cycles in the noise determination are not overlapping.

In order to obtain reliable results, the lamp should be turned on for at least 10 minutes prior to measurement.

- 1 Run the Quick Noise Test with Agilent Lab Advisor (for further information see Online-Help of user interface).

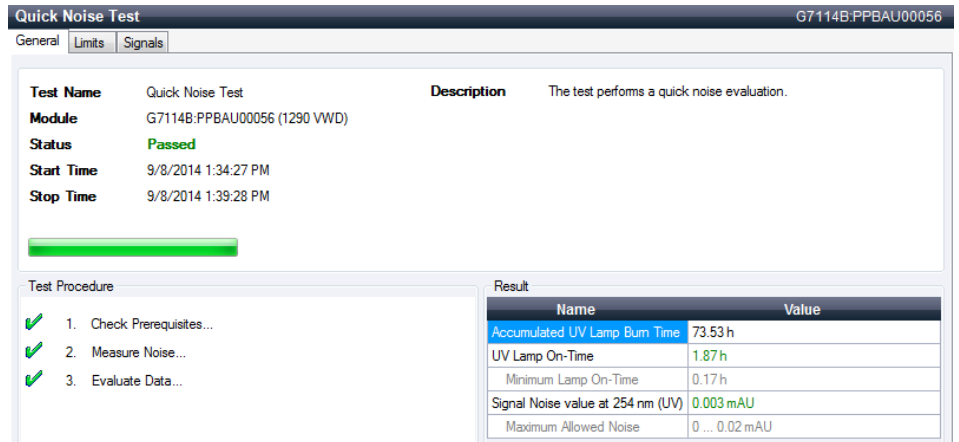

Quick Noise Test G7114B:PPBAU00056

General Limits Signals

Test Name Quick Noise Test **Description** The test performs a quick noise evaluation.

Module G7114B:PPBAU00056 (1290 VWD)

Status Passed

Start Time 9/8/2014 1:34:27 PM

Stop Time 9/8/2014 1:39:28 PM

Test Procedure

- ✓ 1. Check Prerequisites...
- ✓ 2. Measure Noise...
- ✓ 3. Evaluate Data...

Result

Name	Value
Accumulated UV Lamp Burn Time	73.53 h
UV Lamp On-Time	1.87 h
Minimum Lamp On-Time	0.17 h
Signal Noise value at 254 nm (UV)	0.003 mAU
Maximum Allowed Noise	0 ... 0.02 mAU

Figure 32 Quick Noise Test – Results

Test Functions

Quick Noise Test

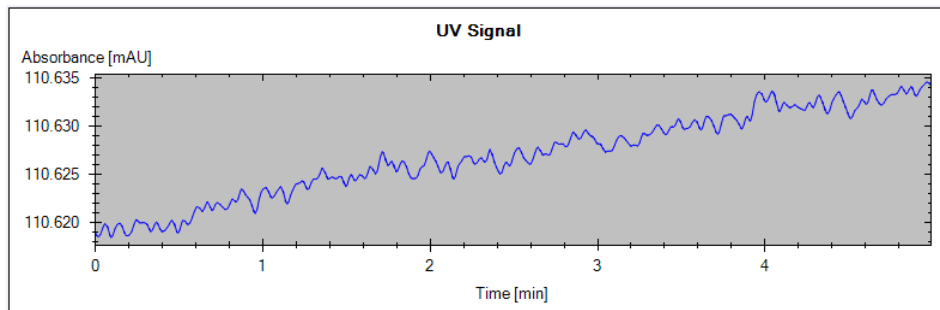

Figure 33 Quick Noise Test – Signal

Dark Current Test

The dark-current test measures the leakage current from the sample and reference circuits. The test is used to check for defective sample or reference diodes or ADC circuits which may cause non-linearity or excessive baseline noise. During the test, the shutter is moved into the light path. Next, the leakage current from both diodes is measured.

- 1 Run the Dark Current Test with the Agilent Lab Advisor (for further information see Online-Help of user interface).

Dark Current Test		G7114B:PPBAU00056	
General Limits Signals			
Test Name	Dark Current Test	Description	The test measures the dark current from the detector optic.
Module	G7114B:PPBAU00056 (1290 VWD)		
Status	Passed		
Start Time	9/8/2014 2:06:28 PM		
Stop Time	9/8/2014 2:06:56 PM		
<div style="background-color: green; width: 100%; height: 10px;"></div>			
Test Procedure		Result	
✓	1. Check Prerequisites...		
✓	2. Perform Dark Current Test...		
✓	3. Evaluate Data...		
		Name	Value
		Maximum Sample Intensity Measured	41 Counts
		Maximum Sample Intensity	7900 Counts
		Maximum Reference Intensity Measured	24 Counts
		Maximum Reference Intensity	7900 Counts

Figure 34 Dark Current Test - Results

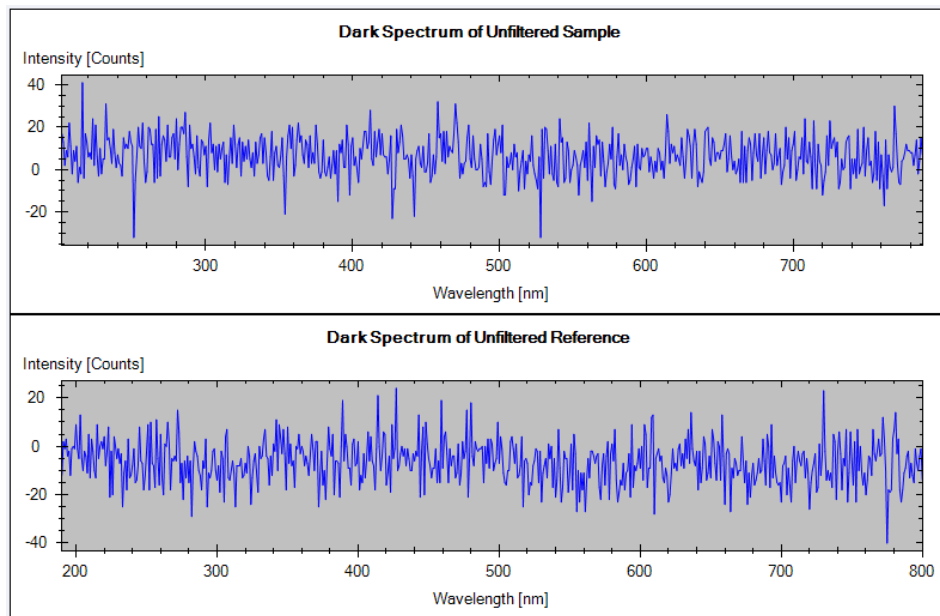

Figure 35 Dark Current Test - Signals

Dark Current Test Failed

Dark Current Test Failed

Probable cause	Suggested actions
1 Defective sample or reference diode.	Replace optical unit.
2 Defective sample or reference ADC board.	Replace optical unit.
3 Defective main board.	Exchange the main board.

Holmium Oxide Test

This test verifies the calibration of the detector against the three wavelength maxima of the built-in holmium oxide filter. The test displays the difference between the expected and measured maxima. The figure below shows a holmium test spectrum.

The Holmium Oxide Test is available in Agilent Lab Advisor (preferred tool).

The test uses the following holmium maxima:

- 360.8 nm
- 418.5 nm
- 536.4 nm

NOTE

See also “Declaration of Conformity for HOX2 Filter” on page 233.

When to do the Test

- after recalibration,
- as part of the Operational Qualification/Performance Verification procedure, or
- after flow cell maintenance or repair.

Interpreting the Results

The test is passed successfully when all three wavelengths are within ± 1 nm of the expected value. This indicates the detector is calibrated correctly.

- 1 Run the Holmium Oxide Test with the Agilent Lab Advisor (for further information see Online- Help of user interface).

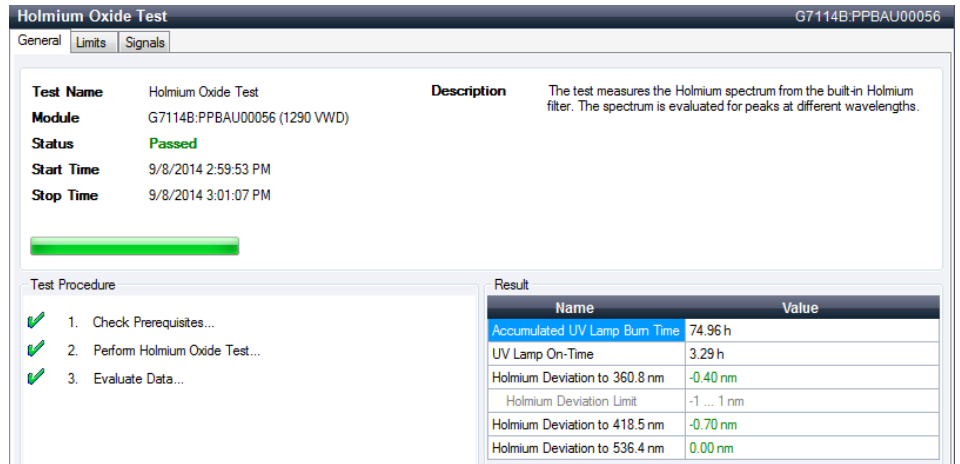

Figure 36 Holmium Oxide Test - Results

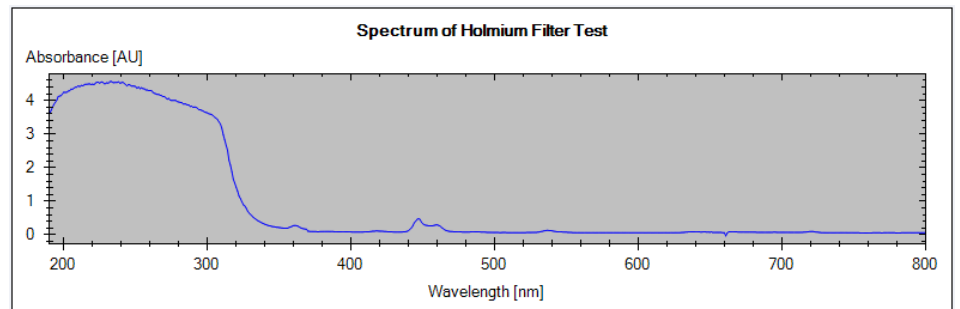

Figure 37 Holmium Oxide Test - Signals

Holmium Oxide Test Failed

Holmium Oxide Test Failed

Probable cause	Suggested actions
1 Detector not calibrated.	Recalibrate the detector.
2 Dirty or defective flow cell.	Repeat the test with the flow cell removed. If the test is OK, exchange the flow cell components.
3 Dirty or defective holmium oxide filter.	Run the holmium oxide filter test. If the test fails, contact your Agilent service representative.
4 Optical misalignment.	Please contact your Agilent service representative.

D/A Converter (DAC) Test

The detector provides analog output of chromatographic signals for use with integrators, chart recorders or data systems. The analog signal is converted from the digital format by the digital-analog-converter (DAC).

The DAC test is used to verify correct operation of the digital-analog-converter by applying a digital test signal to the DAC.

The DAC outputs an analog signal of approximately 50 mV (if the zero offset of the analog output is set to the default value of 5 %) which can be plotted on an integrator. A continuous square wave with an amplitude of 10 μ V and a frequency of approximately 1 cycle/24 seconds is applied to the signal.

The amplitude of the square wave and the peak-to-peak noise are used to evaluate the DAC test.

When If the analog detector signal is noisy or missing.

Preparations Lamp must be on for at least 10 minutes. Connect integrator, chart recorder or data system to the detector analog output.

Test Functions

D/A Converter (DAC) Test

Running the test with Agilent Lab Advisor

- 1 Run the D/A Converter Test with the Agilent Lab Advisor (for further information see Online- Help of user interface).

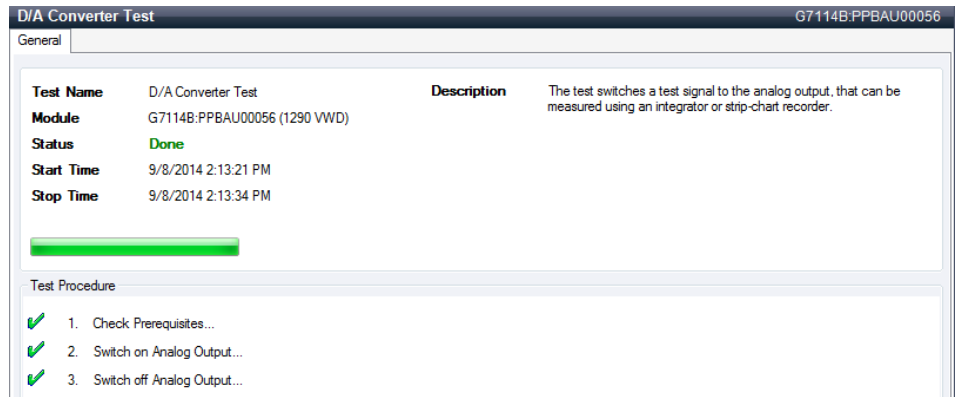

Figure 38 Converter Test - Results

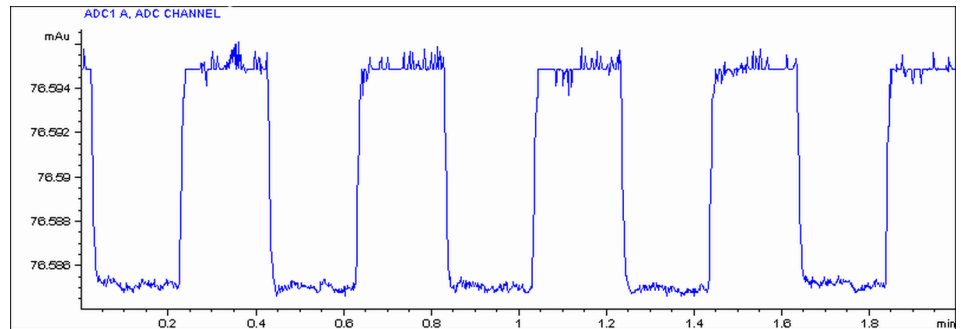

Figure 39 D/A Converter (DAC) Test – Example of Integrator Plot

Running the Test with Instant Pilot

The test can be started via the command line.

- 1 To start the test
TEST: DAC 1
Reply: RA 00000 TEST:DAC 1
- 2 To stop the test
TEST: DAC 0
Reply: RA 00000 TEST:DAC 0

D/A Converter Test Evaluation

Test Evaluation

The noise on the step should be less than 3 μV .

Probable cause	Suggested actions
1 Bad cable or grounding problem between detector and external device.	Check or replace the cable.
2 Defective detector main board.	Please contact your Agilent service representative.

Other Lab Advisor Functions

EMFs - Early Maintenance Feature

The EMFs screen allows you to view and manage the EMF counters for all modules in all systems.

The screenshot shows the EMFs screen with the following data:

Filter						
<input checked="" type="radio"/> All Counters <input type="radio"/> Counters with Limit						
Title		Value	Unit	Limit	Progress	
G7114B Serial # PPBAU00056		72.38	h	0	0%	
G7114B 1290 VWD Accumulated UV Lamp On-Time		4	Count	0	0%	
Number of UV Lamp Ignitions						

Buttons at the bottom: Activate EMF, Deactivate EMF, Refresh Counters

Figure 40 EMFs

9

Maintenance

Introduction to Maintenance	133
Warnings and Cautions	134
Overview of Maintenance	136
Cleaning the Module	137
Remove and Install the Doors	138
Replace the Deuterium Lamp	140
Replace the Flow Cell / Cuvette Holder	143
Repair the Flow Cells	145
Using the Cuvette Holder	149
Correcting Leaks	151
Replace Leak Handling System Parts	153
Replace the Module Firmware	154

This chapter provides general information on maintenance of the detector.

Introduction to Maintenance

The module is designed for easy maintenance. Maintenance can be done from the front with module in place in the system.

NOTE

There are no serviceable parts inside.
Do not open the module.

Warnings and Cautions

WARNING

Toxic, flammable and hazardous solvents, samples and reagents

The handling of solvents, samples and reagents can hold health and safety risks.

- ✓ When working with these substances observe appropriate safety procedures (for example by wearing goggles, safety gloves and protective clothing) as described in the material handling and safety data sheet supplied by the vendor, and follow good laboratory practice.
 - ✓ The volume of substances should be reduced to the minimum required for the analysis.
 - ✓ Do not operate the instrument in an explosive atmosphere.
-

WARNING

Eye damage by detector light

Eye damage may result from directly viewing the UV-light produced by the lamp of the optical system used in this product.

- ✓ Always turn the lamp of the optical system off before removing it.
-

WARNING

Electrical shock

Repair work at the module can lead to personal injuries, e.g. shock hazard, when the cover is opened.

- ✓ Do not remove the cover of the module.
 - ✓ Only certified persons are authorized to carry out repairs inside the module.
-

WARNING**Personal injury or damage to the product**

Agilent is not responsible for any damages caused, in whole or in part, by improper use of the products, unauthorized alterations, adjustments or modifications to the products, failure to comply with procedures in Agilent product user guides, or use of the products in violation of applicable laws, rules or regulations.

- ✓ Use your Agilent products only in the manner described in the Agilent product user guides.
-

CAUTION**Safety standards for external equipment**

- ✓ If you connect external equipment to the instrument, make sure that you only use accessory units tested and approved according to the safety standards appropriate for the type of external equipment.
-

Overview of Maintenance

The following pages describe maintenance (simple repairs) of the detector that can be carried out without opening the main cover.

Table 19 Simple Repairs

Procedures	Typical Frequency	Notes
Deuterium lamp exchange	If noise and/or drift exceeds your application limits or lamp does not ignite.	A wavelength calibration test and an intensity test should be performed after replacement.
Flow cell exchange	If application requires a different flow cell type.	A wavelength calibration test should be performed after replacement.
Cleaning flow cell parts cleaning or exchange	If leaking or if intensity drops due to contaminated flow cell windows.	A pressure tightness test should be done after repair.
Leak sensor drying	If leak has occurred.	Check for leaks.
Leak handling system replacement	If broken or corroded.	Check for leaks.

Cleaning the Module

To keep the module case clean, use a soft cloth slightly dampened with water, or a solution of water and mild detergent. Avoid using organic solvents for cleaning purposes. They can cause damage to plastic parts.

WARNING

Liquid dripping into the electronic compartment of your module can cause shock hazard and damage the module

- ✓ Do not use an excessively damp cloth during cleaning.
- ✓ Drain all solvent lines before opening any connections in the flow path.

NOTE

A solution of 70 % isopropanol and 30 % water might be used if the surface of the module needs to be disinfected.

Remove and Install the Doors

Parts required	p/n	Description
	5067-5737	Door left
	5067-5736	Door right

NOTE

The figures shown in this procedure exemplarily show the Infinity II Multisampler module.

The principle of how to remove and/or install doors works in the same way for all Infinity II modules.

Maintenance

Remove and Install the Doors

1 Press the release buttons and pull the front door out.

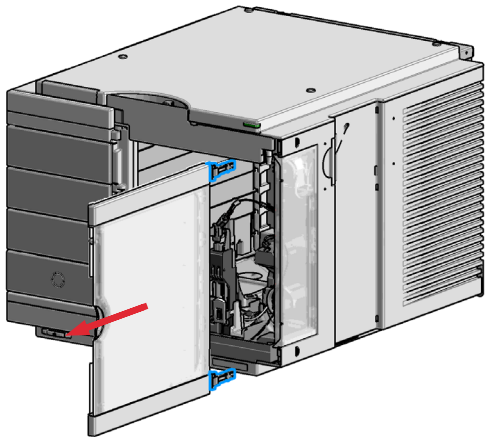
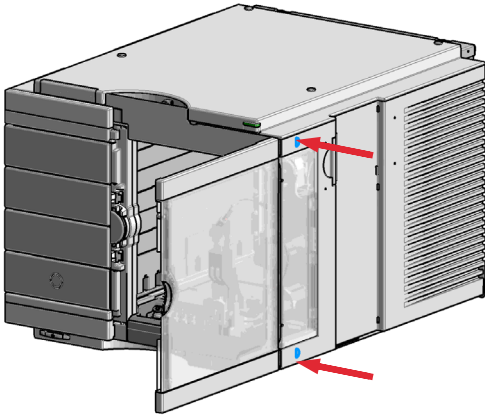

2 For the Installation of the front door. Insert the hinges into their guides and move the door in until the release buttons click into their final position.

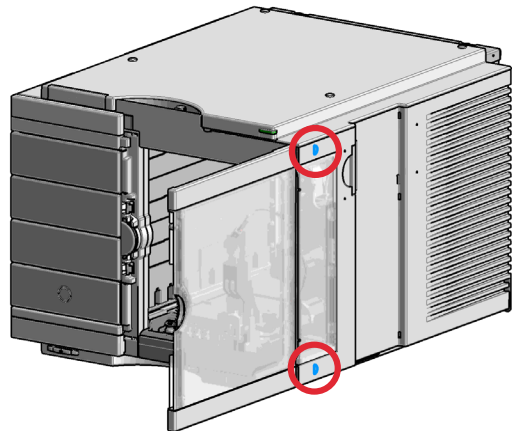
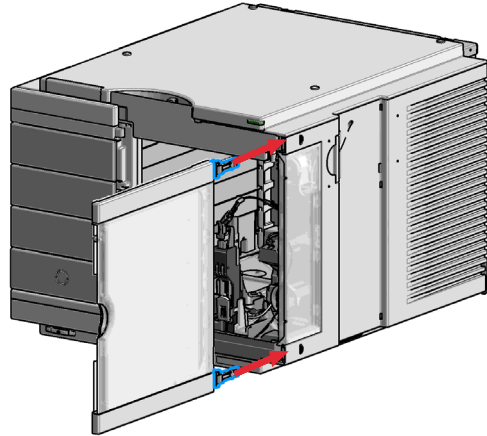

Replace the Deuterium Lamp

When If noise or drift exceeds application limits or lamp does not ignite.

Tools required **Description**
Screwdriver, Pozidriv #1 PT3

Parts required	#	p/n	Description
	1	G1314-60101	Deuterium lamp (with RFID tag)

Preparations Turn the lamp OFF.

WARNING

Injury by touching hot lamp

If the detector has been in use, the lamp may be hot.

- ✓ If so, wait for lamp to cool down.

WARNING

Injury by sharp metal edges

- ✓ Be careful when touching the RFI sheet metal at the rear of the fan. There are sharp edges.

CAUTION

Electronic boards and components are sensitive to electrostatic discharge (ESD).

- ✓ To prevent accidental electrostatic discharge when coming into contact with components inside the instrument, touch one of the metal housing panels at the front of the instrument.

Maintenance

Replace the Deuterium Lamp

1 Open the doors.

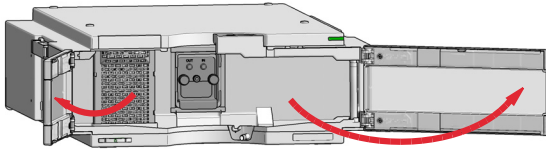

2 Locate the heater fan cover.

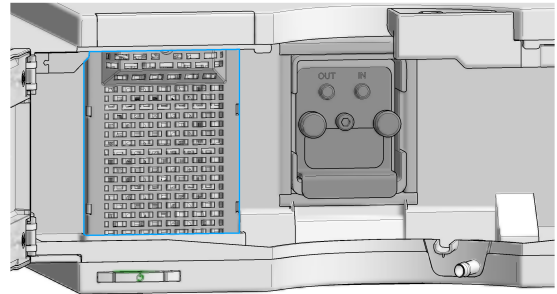

3 Unscrew the fan cover (1.) and remove it (2.).

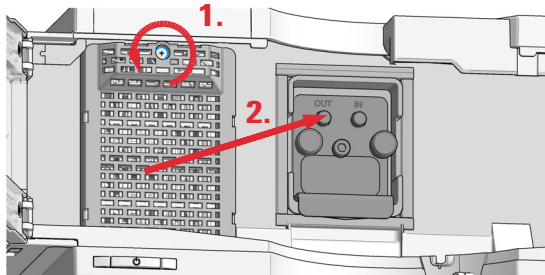

4 Unplug the lamp connector.

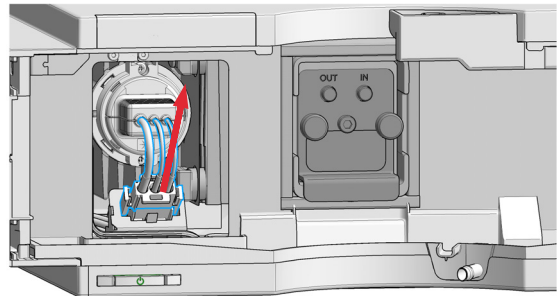

5 Unscrew the two lamp screws (Pozidriv).

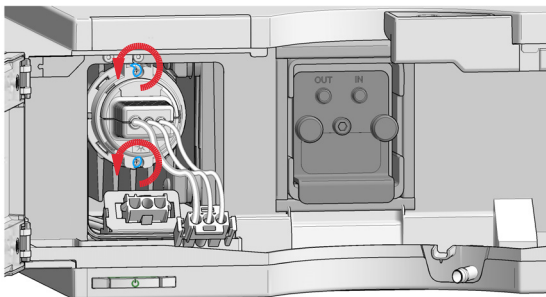

6 Remove the lamp and place it on a clean place.

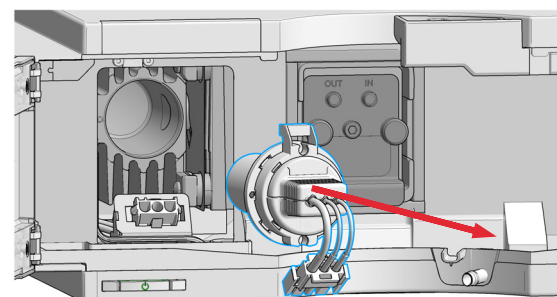

NOTE

Do not touch the glass bulb with your fingers. It may reduce the light output.

- 7 Insert the lamp (RFID tag on top) (1.) and fix the screws (2.).

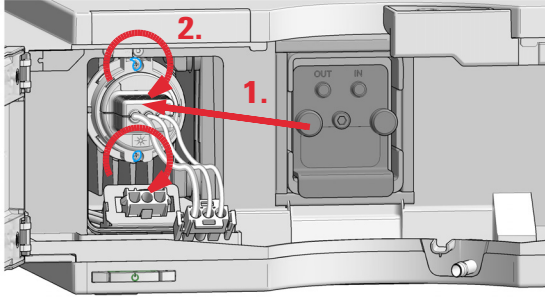

- 8 Reconnect the connector.

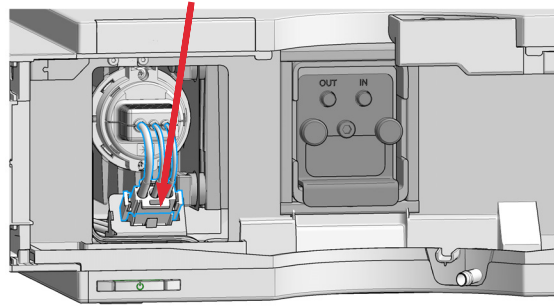

- 9 Replace the fan cover (1.) and fix its screw (2.).

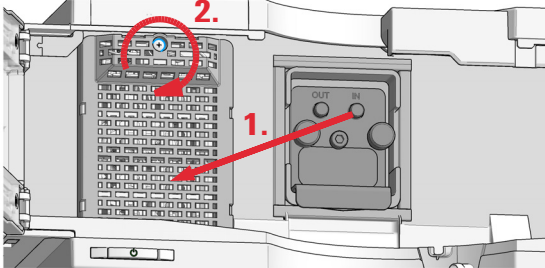

- 10 Close the doors.

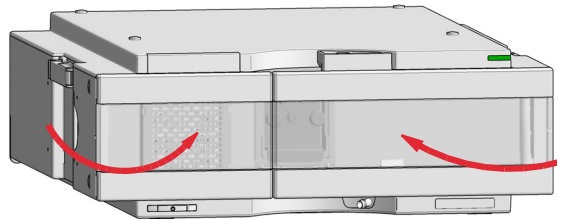

Next Steps:

- 11 Reset the lamp counter as described in the User Interface documentation (required for non-RFID tag lamps only).
- 12 Turn the lamp ON and give the lamp more than 10 minutes to warm-up.
- 13 Perform a Wavelength Re-calibration after lamp warm-up.

NOTE

After lamp on, the detector requires a warm-up time of 60 min. No measurements should be performed during this time.

Replace the Flow Cell / Cuvette Holder

When If application needs a different type of flow cell or the flow cell needs repair.

Tools required	p/n	Description
		Wrench, 1/4 inch for capillary connections
OR	5043-0915	Fitting mounting tool

Parts required	#	Description
	1	Flow cell

For flow cell details see:

- “Standard Flow Cell 10 mm / 14 μ L” on page 158
- “Micro Flow Cell 3 mm / 2 μ L” on page 160
- “Semi-micro Flow Cell (Parts)” on page 162
- “High Pressure Flow Cell (Parts)” on page 164
- “Bio Standard Flow Cell” on page 166
- “Bio Micro Flow Cell” on page 168

Preparations Turn the lamp OFF.

1 Open the doors.

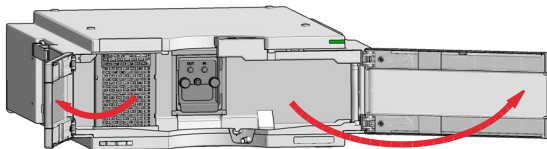

2 Disconnect the inlet capillary and outlet tubing from the flow cell.

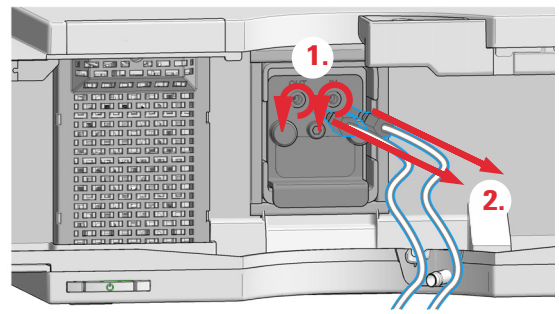

Replace the Flow Cell / Cuvette Holder

3 Unscrew the two thumb screws.

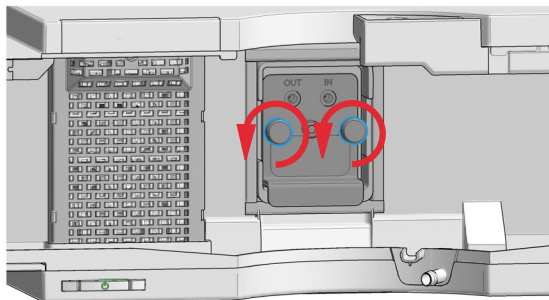

4 Pull the flow cell out of its location.

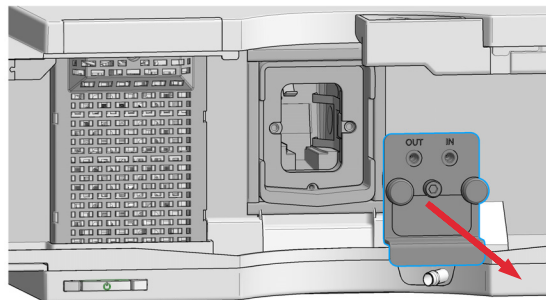

5 Insert the flow cell into its location and press it in the center of the flow cell.

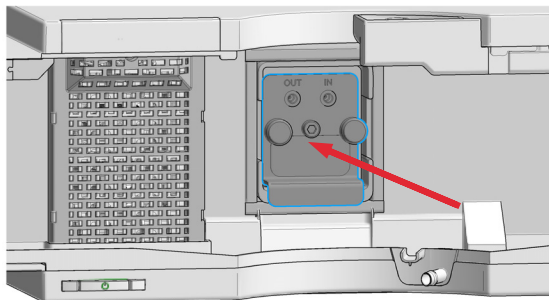

6 Fix the two thumb screws parallel and tight.

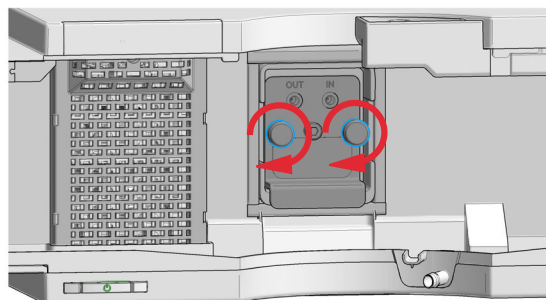

7 Reconnect the inlet capillary and the outlet tubing.

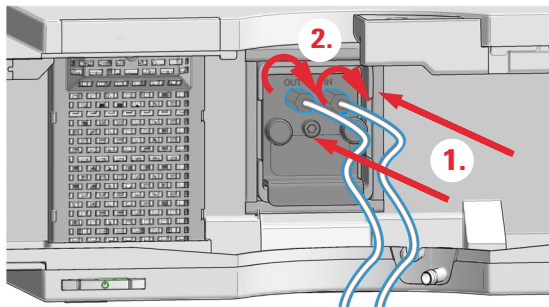

8 Close the doors.

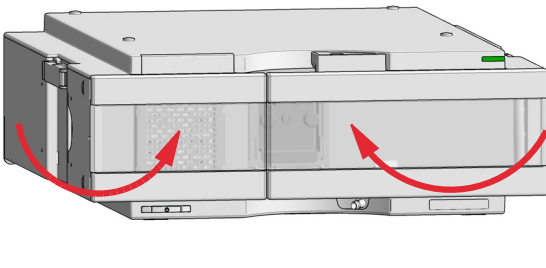

Next Steps:

- 9 Configure the flow cell. For further information see Agilent Information Center or the online help of your CDS.
- 10 Perform a **Wavelength Verification-Calibration** to check the correct position of the flow cell/cuvette holder.

Repair the Flow Cells

Parts required

#	Description
1	Flow cell

For details on flow cells see:

- “Standard Flow Cell 10 mm / 14 μ L” on page 158
- “Micro Flow Cell 3 mm / 2 μ L” on page 160
- “Semi-micro Flow Cell (Parts)” on page 162
- “High Pressure Flow Cell (Parts)” on page 164
- “Bio Standard Flow Cell” on page 166
- “Bio Micro Flow Cell” on page 168

NOTE

The shown cell parts will differ depending upon the flow cell type. For detailed parts schematics, refer to above mentioned pages.

Maintenance

Repair the Flow Cells

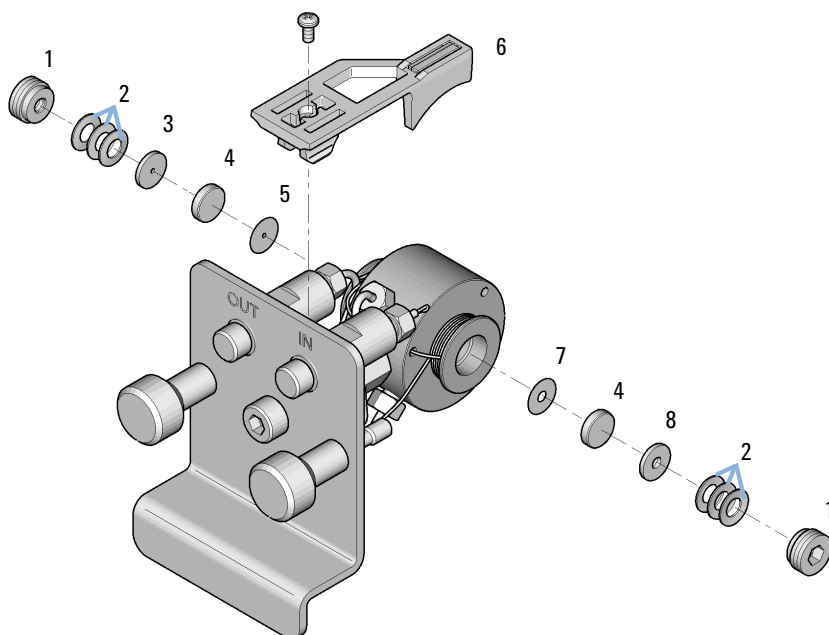

1	Cell screw
2	Conical springs
3	Ring #1 PEEK
4	Window Quartz
5	Gasket #1 (small hole)
6	RFID tag
7	Gasket #2 (large hole)
8	Ring #2 PEEK

- 1 Disassembling the Flow Cell.
 - a Unscrew the cell screw using a 4-mm hexagonal wrench.
 - b Remove the SST rings using a pair of tweezers.

CAUTION

Scratched window surfaces by tweezers

Window surfaces can easily be scratched by using tweezers for removing the windows.

✓ Do not use tweezers to remove windows

- c Use adhesive tape to remove the peek ring, the window and the gasket.
 - d Repeat step a through step c for the other window (keep the parts separate - otherwise they could be mixed!).
- 2 Cleaning the Flow Cell Parts
 - a Pour isopropanol into the cell hole and wipe clean with a piece of lint-free cloth.
 - b Clean the windows with ethanol or methanol. Dry it with a piece of lint-free cloth.

NOTE

Always use new gaskets.

- 3 Reassembling the Flow Cell
 - a Hold the flow cell cassette horizontally and place gasket in position. Ensure both cell holes can be seen through the holes of gasket.

NOTE

The semi-micro #1 and #2 gaskets (items 6 and 7, “Semi-micro Flow Cell (Parts)” on page 162) look very similar. Do not mix them up.

- b Place the window on gasket.
 - c Place the peek ring on the window.
 - d Insert the conical springs. Make sure the conical springs point towards the window. Otherwise tightening the cell screw might break the window.

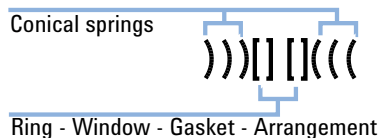

Figure 41 Orientation of conical springs

- e Screw the cell screw into the flow cell and tighten the screw.

Maintenance**Repair the Flow Cells**

- 4 Repeat the procedure for the other cell side.
- 5 Reconnect the capillaries.
- 6 Perform a leak test. If OK, insert the flow cell.
- 7 Perform “[Wavelength Verification-Calibration](#)” on page 118 to check the correct positioning of the flow cell.
- 8 Replace the front cover.

Using the Cuvette Holder

This cuvette holder can be placed instead of a flow cell in the variable wavelength detector. Standard cuvettes with standards in it, for example, National Institute of Standards & Technology (NIST) holmium oxide solution standard, can be fixed in it.

This can be used for wavelength verifications.

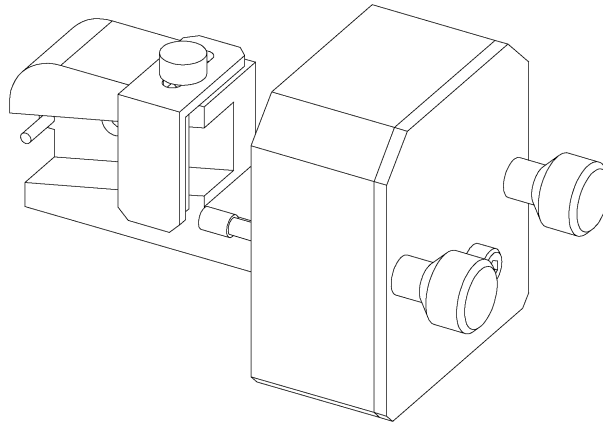

When If your own standard should be used to checkout the instrument.

Parts required	#	p/n	Description
	1	G1314-60200	Cuvette Holder
	1		Cuvette with the "standard", e.g. NIST certified holmium oxide sample

- Preparations**
- Remove the normal flow cell.
 - Have cuvette with standard available.

Maintenance

Using the Cuvette Holder

- 1 Locate the cuvette holder on the desk.

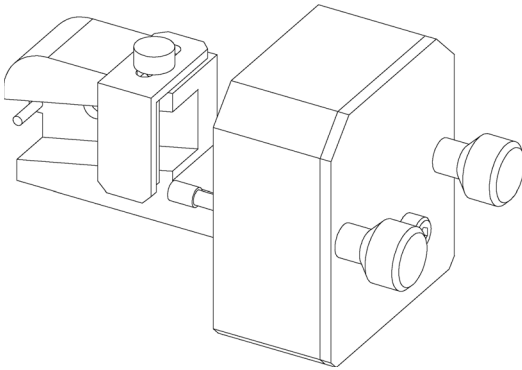

- 2 Unscrew the bracket.

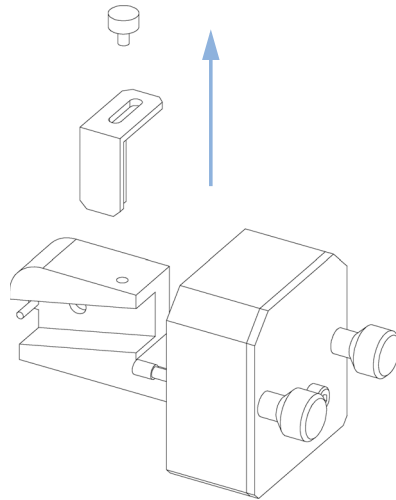

- 3 Insert the cuvette with the sample into the holder. The clear side of the cuvette must be visible.

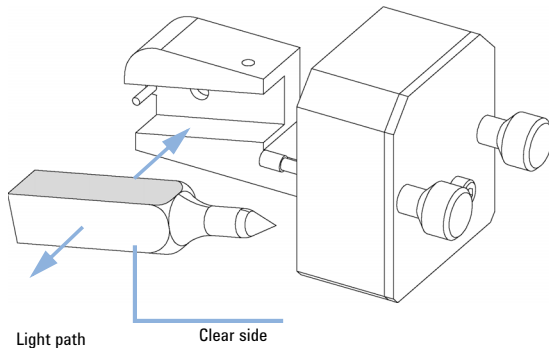

- 4 Replace the bracket and fix the cuvette.

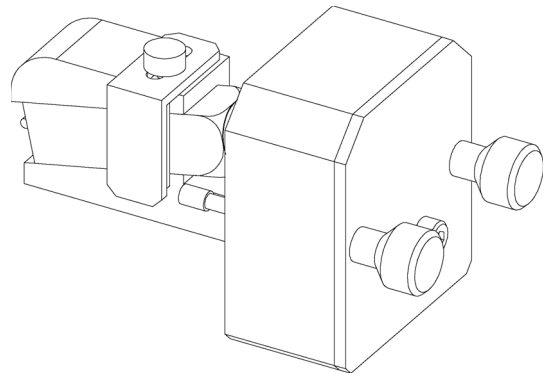

Next Steps:

- 5 Install the cuvette holder in the instrument.
- 6 Perform your Wavelength Verification/Calibration (see "Wavelength Verification-Calibration" on page 118) to check the correct position of the cuvette holder.

Correcting Leaks

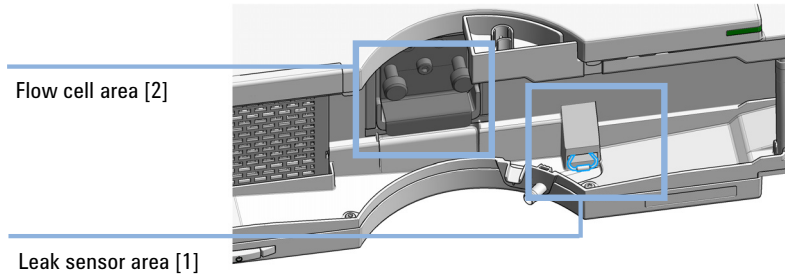

Figure 42 Correcting leaks

When If a leakage has occurred in the flow cell area or at the capillary connections.

Tools required

Description
Tissue
Wrench, 1/4 inch for capillary connections

<p>1 Open the doors.</p>	<p>2 Use tissue to dry the leak sensor area [1].</p> <p>3 Observe the capillary connections and the flow cell area [2] for leaks and correct, if required.</p>
---------------------------------	--

4 Close the doors.

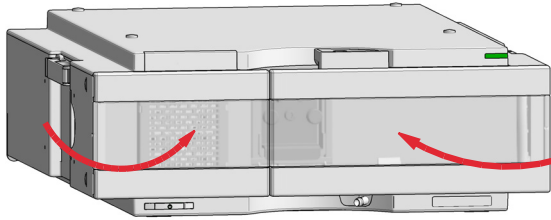

Replace Leak Handling System Parts

Parts required	p/n	Description
	5043-0856	Leak Adapter
	5063-6527	Tubing, Silicon Rubber, 1.2 m, ID/OD 6/9 mm

Preparations Open or remove the doors

1 Locate the Leak Adapter [1] and Tubing [2]

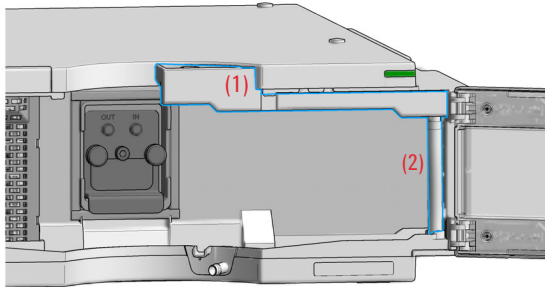

Next Steps:

- 2** Press the Leak Adapter [1] down and remove it together with the tubing.
- 3** Install the Leak Adapter by pressing it into the Main Cover.
- 4** Insert the Tubing [2] (ca. 85 mm required for replacement) between Leak Adapter outlet and Leak Pan.
- 5** Insert/close the doors.

Replace the Module Firmware

When	<p>The installation of newer firmware might be necessary</p> <ul style="list-style-type: none"> • if a newer version solves problems of older versions or • to keep all systems on the same (validated) revision. <p>The installation of older firmware might be necessary</p> <ul style="list-style-type: none"> • to keep all systems on the same (validated) revision or • if a new module with newer firmware is added to a system or • if third party control software requires a special version.
-------------	--

Tools required	Description
	Agilent Lab Advisor software

Parts required	#	Description
	1	Firmware, tools and documentation from Agilent web site

Preparations	Read update documentation provided with the Firmware Update Tool.
---------------------	---

To upgrade/downgrade the module's firmware carry out the following steps:

- 1 Download the required module firmware, the latest FW Update Tool and the documentation from the Agilent web.
<http://www.agilent.com/en-us/firmwareDownload?whid=69761>
- 2 For loading the firmware into the module follow the instructions in the documentation.

Module Specific Information

Table 20 Module Specific Information (G7114A/B)

	G7114B	G7114A
Initial firmware	D.06.70	D.07.01
Compatibility with 1100 / 1200 series modules	When using the G7114A/B in a system, all other modules must have firmware from set 6.50 or above (main and resident). Otherwise the communication will not work.	
Conversion / emulation	Possible via Lab Advisor software: <ul style="list-style-type: none"> • G7114B: G1314E/F • G7114A: G1314F 	

10

Parts and Materials for Maintenance

Overview of Maintenance Parts	156
Standard Flow Cell 10 mm / 14 μ l	158
Micro Flow Cell 3 mm / 2 μ L	160
Semi-micro Flow Cell (Parts)	162
High Pressure Flow Cell (Parts)	164
Bio Standard Flow Cell	166
Bio Micro Flow Cell	168
Cuvette Holder (Parts)	170
Accessory Kit	171

This chapter provides information on parts for maintenance.

Overview of Maintenance Parts

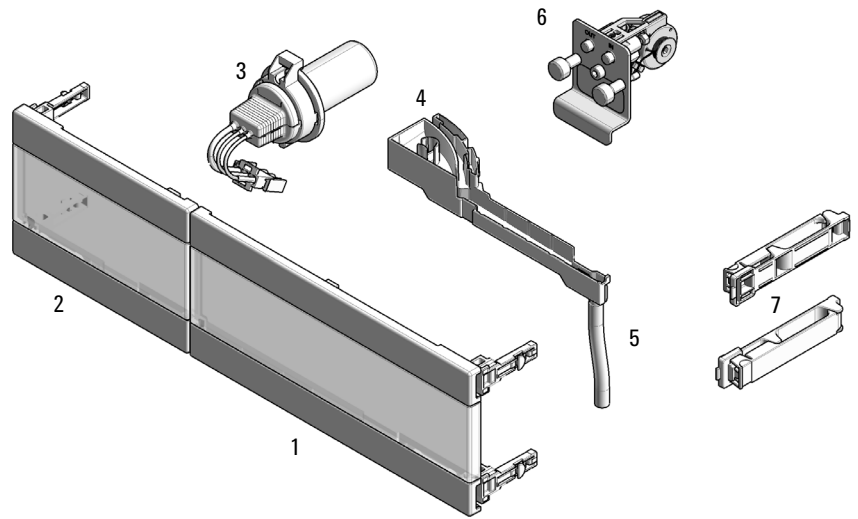

Figure 43 Overview of maintenance parts

Parts and Materials for Maintenance

Overview of Maintenance Parts

Item	p/n	Description	
	1	5067-5736	Door right
	2	5067-5737	Door left
	3	G1314-60101	Deuterium lamp (with RFID tag)
	4	5043-0856	Leak Adapter
	5	5063-6527	Tubing, Silicon Rubber, 1.2 m, ID/OD 6/9 mm
	6	G1314-60186	Standard flow cell 10 mm, 14 μ L, 40 bar (with RFID tag)
OR	6	G1314-60187	Micro flow cell 3 mm, 2 μ L, 120 bar (with RFID tag)
OR	6	G1314-60183	Semi-micro flow cell 6 mm, 5 μ L (with RFID tag)
OR	6	G1314-60182	High pressure flow cell 10 mm, 14 μ L, 400 bar (with RFID tag)
OR	6	G1314-60023	Prep flow cell 0.06 mm
OR	6	G1314-60025	Prep flow cell 0.3 mm
OR	6	G1314-60024	Prep flow cell 3 mm
OR	6	G1314-60188	Bio standard flow cell VWD, 10 mm 14 μ L, RFID
OR	6	G1314-60189	Bio micro flow cell VWD, 3 mm, 2 μ L, RFID
		5062-8535	Waste accessory kit (Flow Cell to Waste)
	7	5043-1013	Tubing Clip

Standard Flow Cell 10 mm / 14 μ l

Item	p/n	Description
	G1314-60186	Standard flow cell 10 mm, 14 μ L, 40 bar (with RFID tag)
	5062-8522	Capillary column - detector PEEK 600 mm lg, 0.17 mm i.d., 1/16 inch o.d.
	G1314-65061	Cell Repair Kit, includes 2x Gasket #1, 2x Gasket #2, 2x Window Quartz
1	G1314-65062	Cell screw kit
2	79853-29100	Conical spring kit, 10/pk
3	G1314-65065	Ring #1 kit (OUT large hole, i.d. 2.4 mm) PEEK, 2/pk
4	79853-68742	Window quartz kit, 2/pk
5	G1314-65063	Gasket #1 kit (OUT large hole, i.d. 2.4 mm) KAPTON, 2/pk
6	0515-4780	Screw for Clip, M2.2, 4.5 mm long
7	G1314-44010	Clip for RFI ID tag
8	G1314-65064	Gaskets #2 IN (small hole i.d. 1 mm), KAPTON 10/pk
9	G1314-65066	Ring #2 kit (IN small hole, i.d. 1 mm) PEEK, 2/pk

Parts and Materials for Maintenance

Standard Flow Cell 10 mm / 14 μ l

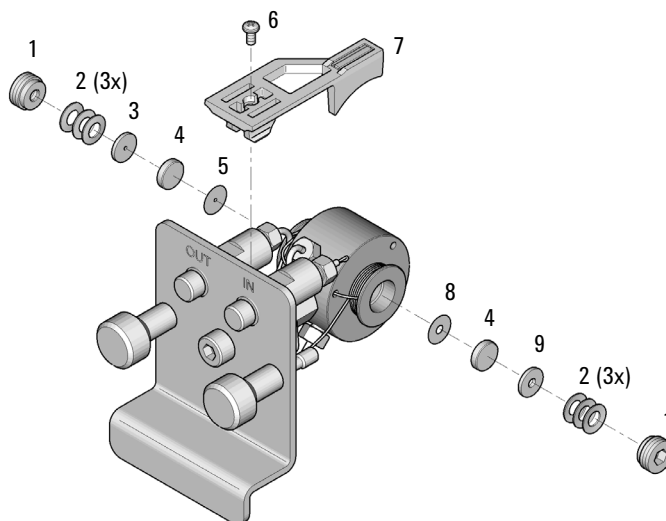

Figure 44 Standard Flow Cell

Micro Flow Cell 3 mm / 2 μ L

Item	p/n	Description
	G1314-60187	Micro flow cell 3 mm, 2 μ L, 120 bar (with RFID tag)
	5021-1823	Capillary column – detector SST 400 mm lg, 0.12 mm i.d.
1	79883-22402	Window screw
2	5062-8553	Washer kit (10/pk)
3	79883-28801	Compression washer
4	79883-22301	Window holder
5	1000-0488	Quartz window
6	79883-68702	Gasket BACK (PTFE), 1.8 mm hole, outlet side (12/pk)
7	0515-4780	Screw for Clip, M2.2, 4.5 mm long
8	G1314-44010	Clip for RFI ID tag
9	G1315-68710	Gasket FRONT (PTFE), 1.3 mm hole, inlet side (12/pk)
	G1314-87301	Capillary IN (0.12 mm, 310 mm lg)
	G1314-87302	Capillary OUT (0.17 mm, 120 mm lg)
	G1315-68713	Cell repair kit semi-micro, includes window screw kit, Gasket Kit BACK, Gasket Kit FRONT and 4 mm hexagonal wrench
	79883-68703	Window screw kit, includes 2 quartz windows, 2 compression washers, 2 window holders, 2 window screws and 10 washers

Micro Flow Cell 3 mm / 2 μ L

Figure 45 Micro Flow Cell

Semi-micro Flow Cell (Parts)

NOTE

The semi-micro #1 and #2 gaskets (items 6 and 7) look very similar. Do not mix them up.

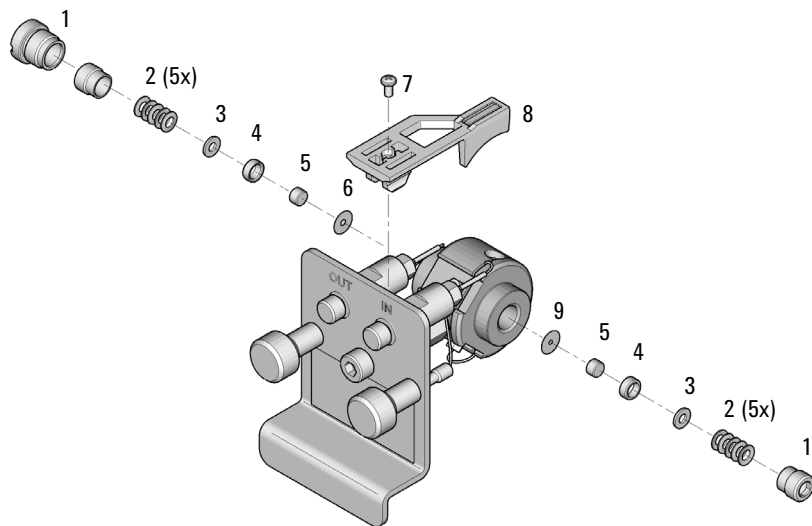
Item	p/n	Description
	G1314-60183	Semi-micro flow cell 6 mm, 5 μ L (with RFID tag)
	5021-1823	Capillary column – detector SST 400 mm lg, 0.12 mm i.d.
1	G1314-20047	Cell screw
	G1314-65056	Semi-micro cell kit, includes two quartz windows, one gasket #1, one #2 and two PTFE gaskets.
2	79853-29100	Conical spring kit, 10/pk
3	79853-22500	Ring SST, 2/pk
4	79853-68743	PTFE gasket (round hole i.d. 2.5 mm, o.d. 8 mm), (10/pk)
5	79853-68742	Window quartz kit, 2/pk
6		Semi-micro #1 gasket (long hole 1.5 x 3.5 mm), PTFE
7		Semi-micro #2 gasket (long hole 2 x 4 mm), PTFE
8	G1314-44010	Clip for RFI ID tag
9	0515-4780	Screw for Clip, M2.2, 4.5 mm long

Parts and Materials for Maintenance

Semi-micro Flow Cell (Parts)

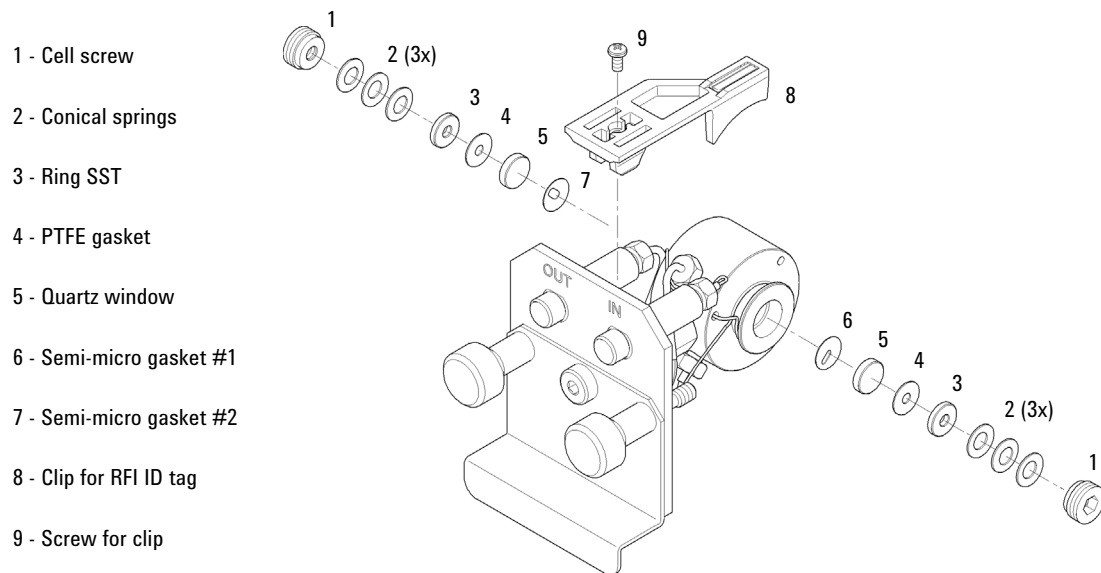

Figure 46 Semi-micro Flow Cell

High Pressure Flow Cell (Parts)

Item	p/n	Description
	G1314-60182	High pressure flow cell 10 mm, 14 μ L, 400 bar (with RFID tag)
	G1315-87311	Capillary ST 0.17 mm x 380 mm S/S
1	G1314-20047	Cell screw
	G1314-65054	Cell kit Agilent, comprises: two windows, two KAPTON gaskets and two PEEK rings
2		Ring PEEK kit
3		Window quartz kit
4		Gasket kit, KAPTON
5	G1314-44010	Clip for RFI ID tag
6	0515-4780	Screw for Clip, M2.2, 4.5 mm long

Parts and Materials for Maintenance

High Pressure Flow Cell (Parts)

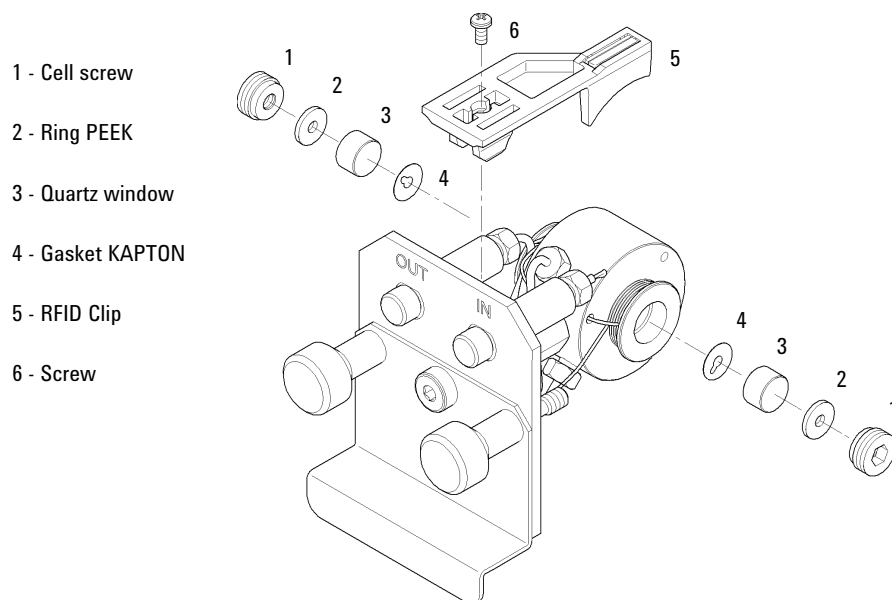

Figure 47 High Pressure Flow Cell

Bio Standard Flow Cell

Item	#	p/n	Description
1	2	G1314-20047	Cell screw
2	6	5022-3942	Disc spring
3	1	G1314-20046	Ring (Out)
4	2	5190-0939	Sapphire window VWD
5	1	G1314-40044	Gasket Out Bio
6	1	G1314-40043	Gasket In Bio
7	1	G1314-20045	Ring (In)
8	1	G1314-60054	Cell Block Assembly VWD MP35N Fitting
9	1	5500-1297	Capillary MP35N 0.3 x 120 mm
10	1	G1314-20011	Cell shaft
11	1	G1314-60058	Cell-Plate Assembly Bio
12	2	0100-1259	Blank nut (plastic)
13	1	0515-1096	SCR-SKT-HD HEX M5X0.8 10 SST PSVT
14	1	G1314-87012	Label Standard RFID Bio
15	1	0515-4780	Screw for Clip, M2.2, 4.5 mm long
16	1	0960-2971	RF Transponder
17	1	G1314-44010	Clip for RFI ID tag
	1	0470-0960	Sealant Methacrylate Ester Liquid

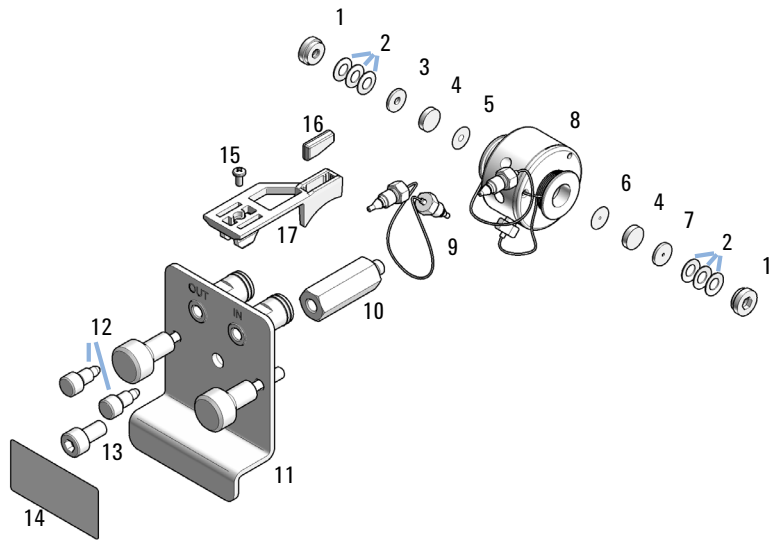
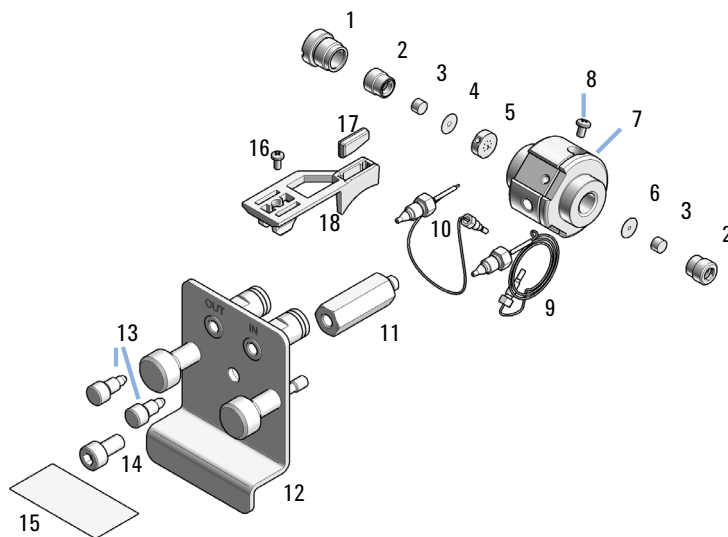

Figure 48 Bio Standard Flow Cell

Bio Micro Flow Cell

Item	#	p/n	Description
1	1	79883-21701	Screw-Bushing 6
2	2	G1315-60021	Cell screw assembly (comprises window screw, spring washers, compression washer, window holder and quartz window)
3	2	5190-0921	Sapphire window
4	1	79883-07101	Gasket
5	1	G1314-27201	VWD Cell Insert 3 mm MP35N
6	1	G1315-07101	Gasket Front 1.3
7	1	G1314-27700	VWD Cell Body 3 mm
8	1	0515-1056	Screw M 2.5, 4 mm lg for cell body/clamp
9	1	G1314-67003	Cap In VWD 3 mm MP35N
10	1	G1314-67004	Cap Out VWD 3 mm MP35N
11	1	G1314-20011	Cell shaft
12	1	G1314-60058	Cell-Plate Assembly Bio
13	2	0100-1259	Plastic fitting
14	1	0515-1096	SCR-SKT-HD HEX M5X0.8 10 SST PSVT
15	1	G1314-87013	Label micro RFID Bio
16	1	0515-4780	Screw for Clip, M2.2, 4.5 mm long
17	1	0960-2971	RF Transponder
18	1	G1314-44010	Clip for RFI ID tag
	1	0470-0960	Sealant Methacrylate Ester Liquid

**Figure 49** Bio Micro Flow Cell

Cuvette Holder (Parts)

For information the use of the cuvette holder, refer to “Using the Cuvette Holder” on page 149.

p/n	Description
G1314-60200	Cuvette Holder

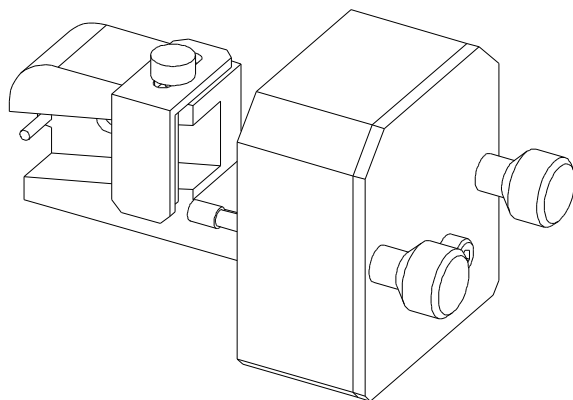

Figure 50 Cuvette Holder

Accessory Kit

Accessory kit (G7114-68755) contains some accessories and tools needed for installation and repair of the module.

p/n	Description
5062-8535	Waste accessory kit
5063-6527	Tubing, Silicon Rubber, 1.2 m, ID/OD 6/9 mm (see item 4 in Figure 43 on page 156)
5181-1516	CAN cable, Agilent module to module, 0.5 m
5500-1155	Tube Connector, 90 degree, ID 6.4
5043-1013	Tubing Clip (see item 7 in Figure 43 on page 156)
0100-1516	Finger-tight fitting PEEK, 2/pk



11

Identifying Cables

Cable Overview	173
Analog Cables	175
Remote Cables	177
CAN Cable	181
RS-232 Cables	182
USB Cables	183

This chapter provides information on cables used with the Agilent 1200 Infinity Series modules.

Cable Overview

NOTE

Never use cables other than the ones supplied by Agilent Technologies to ensure proper functionality and compliance with safety or EMC regulations.

Analog cables

p/n	Description
35900-60750	Agilent 35900A A/D converter
01046-60105	Analog cable (BNC to general purpose, spade lugs)

Remote cables

p/n	Description
5188-8029	ERI to general purpose
5188-8044	Remote Cable ERI – ERI
5188-8045	Remote Cable APG – ERI
5188-8059	ERI-Extension-Cable 1.2 m
5061-3378	Remote Cable to 35900 A/D converter
01046-60201	Agilent module to general purpose
5188-8057	Fraction Collection ERI remote Y-cable

CAN cables

p/n	Description
5181-1516	CAN cable, Agilent module to module, 0.5 m
5181-1519	CAN cable, Agilent module to module, 1 m

LAN cables

p/n	Description
5023-0203	Cross-over network cable, shielded, 3 m (for point to point connection)
5023-0202	Twisted pair network cable, shielded, 7 m (for point to point connection)

RS-232 cables
(not for
FUSION board)

p/n	Description
RS232-61601	RS-232 cable, 2.5 m Instrument to PC, 9-to-9 pin (female). This cable has special pin-out, and is not compatible with connecting printers and plotters. It is also called "Null Modem Cable" with full handshaking where the wiring is made between pins 1-1, 2-3, 3-2, 4-6, 5-5, 6-4, 7-8, 8-7, 9-9.
5181-1561	RS-232 cable, 8 m

USB cables

p/n	Description
5188-8050	USB A M-USB Mini B 3 m (PC-Module)
5188-8049	USB A F-USB Mini B M OTG (Module to Flash Drive)

Analog Cables

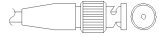

One end of these cables provides a BNC connector to be connected to Agilent modules. The other end depends on the instrument to which connection is being made.

Agilent Module to 35900 A/D converters

p/n 35900-60750	35900	Pin Agilent module	Signal Name
	1		Not connected
	2	Shield	Analog -
	3	Center	Analog +

Identifying Cables
Analog Cables

Agilent Module to BNC Connector

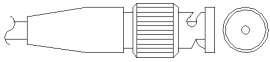
p/n 8120-1840	Pin BNC	Pin Agilent module	Signal Name
	Shield	Shield	Analog -
	Center	Center	Analog +

Agilent Module to General Purpose

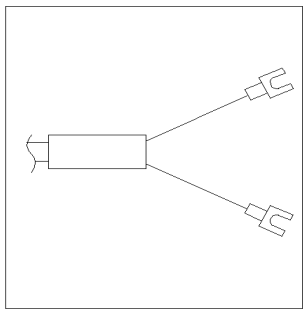
p/n 01046-60105	Pin	Pin Agilent module	Signal Name
	1		Not connected
	2	Black	Analog -
	3	Red	Analog +

Remote Cables

ERI (Enhanced Remote Interface)

- 5188-8029 ERI to general purpose (D-Sub 15 pin male - open end)
- 5188-8044 ERI to ERI (D_Sub 15 pin male - male)
- 5188-8059 ERI-Extension-Cable 1.2 m (D-Sub15 pin male / female)

p/n 5188-8029	pin	Color code	Enhanced Remote	Classic Remote	Active (TTL)
<p>D-Sub female 15way user's view to connector</p>	1	white	IO1	START REQUEST	Low
	2	brown	IO2	STOP	Low
	3	green	IO3	READY	High
	4	yellow	IO4	POWER ON	High
	5	grey	IO5	NOT USED	
	6	pink	IO6	SHUT DOWN	Low
	7	blue	IO7	START	Low
	8	red	IO8	PREPARE	Low
	9	black	1 wire DATA		
	10	violet	DGND		
	11	grey-pink	+5V ERI out		
	12	red-blue	PGND		
	13	white-green	PGND		
	14	brown-green	+24V ERI out		
	15	white-yellow	+24V ERI out		
	NC	yellow-brown			

- 5188-8045 ERI to APG (Connector D_Subminiature 15 pin (ERI), Connector D_Subminiature 9 pin (APG))

p/n 5188-8045	Pin (ERI)	Signal	Pin (APG)	Active (TTL)
	10	GND	1	
	1	Start Request	9	Low
	2	Stop	8	Low
	3	Ready	7	High
	5	Power on	6	High
	4	Future	5	
	6	Shut Down	4	Low
	7	Start	3	Low
	8	Prepare	2	Low
	Ground	Cable Shielding	NC	

- 5188-8057 ERI to APG and RJ45 (Connector D_Subminiature 15 pin (ERI), Connector D_Subminiature 9 pin (APG), Connector plug Cat5e (RJ45))

Table 21 5188-8057 ERI to APG and RJ45

p/n 5188-8057	Pin (ERI)	Signal	Pin (APG)	Active (TTL)	Pin (RJ45)
	10	GND	1		5
	1	Start Request	9	High	
	2	Stop	8	High	
	3	Ready	7	High	
	4	Fraction Trigger	5	High	4
	5	Power on	6	High	
	6	Shut Down	4	High	
	7	Start	3	High	
	8	Prepare	2	High	
	Ground	Cable Shielding	NC		



One end of these cables provides a Agilent Technologies APG (Analytical Products Group) remote connector to be connected to Agilent modules. The other end depends on the instrument to be connected to.

Identifying Cables

Remote Cables

Agilent Module to Agilent 35900 A/D Converters

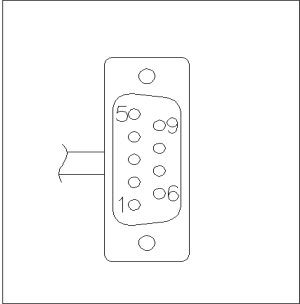
p/n 5061-3378	Pin 35900 A/D	Pin Agilent module	Signal Name	Active (TTL)
	1 - White	1 - White	Digital ground	
	2 - Brown	2 - Brown	Prepare run	Low
	3 - Gray	3 - Gray	Start	Low
	4 - Blue	4 - Blue	Shut down	Low
	5 - Pink	5 - Pink	Not connected	
	6 - Yellow	6 - Yellow	Power on	High
	7 - Red	7 - Red	Ready	High
	8 - Green	8 - Green	Stop	Low
	9 - Black	9 - Black	Start request	Low

Agilent Module to General Purpose

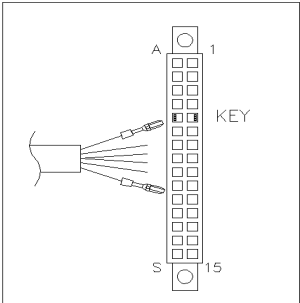
p/n 01046-60201	Wire Color	Pin Agilent module	Signal Name	Active (TTL)
	White	1	Digital ground	
	Brown	2	Prepare run	Low
	Gray	3	Start	Low
	Blue	4	Shut down	Low
	Pink	5	Not connected	
	Yellow	6	Power on	High
	Red	7	Ready	High
	Green	8	Stop	Low
	Black	9	Start request	Low

CAN Cable

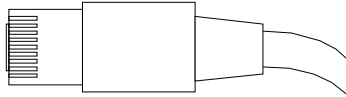

Both ends of this cable provide a modular plug to be connected to Agilent modules CAN or LAN connectors.

CAN Cables

p/n	Description
5181-1516	CAN cable, Agilent module to module, 0.5 m
5181-1519	CAN cable, Agilent module to module, 1 m

LAN Cables

p/n	Description
5023-0203	Cross-over network cable, shielded, 3 m (for point to point connection)
5023-0202	Twisted pair network cable, shielded, 7 m (for point to point connection)

RS-232 Cables

p/n	Description
RS232-61601	RS-232 cable, 2.5 m Instrument to PC, 9-to-9 pin (female). This cable has special pin-out, and is not compatible with connecting printers and plotters. It is also called "Null Modem Cable" with full handshaking where the wiring is made between pins 1-1, 2-3, 3-2, 4-6, 5-5, 6-4, 7-8, 8-7, 9-9.
5181-1561	RS-232 cable, 8 m

USB Cables

To connect a USB Flash Drive use a USB OTG cable with Mini-B plug and A socket.

p/n	Description
5188-8050	USB A M-USB Mini B 3 m (PC-Module)
5188-8049	USB A F-USB Mini B M OTG (Module to Flash Drive)

12 Hardware Information

Firmware Description	185
Electrical Connections	188
Rear View of the Module	189
Information on Instrument Serial Number	189
Interfaces	191
Overview Interfaces	193
ERI (Enhanced Remote Interface)	196
USB (Universal Serial Bus)	198
Setting the 6-bit Configuration Switch	199
Special Settings	201
Instrument Layout	203
Early Maintenance Feedback (EMF)	204

This chapter describes the detector in more detail on hardware and electronics.

Firmware Description

The firmware of the instrument consists of two independent sections:

- a non-instrument specific section, called *resident system*
- an instrument specific section, called *main system*

Resident System

This resident section of the firmware is identical for all Agilent 1100/1200/1220/1260/1290 series modules. Its properties are:

- the complete communication capabilities (CAN, LAN, USB and RS- 232)
- memory management
- ability to update the firmware of the 'main system'

Main System

Its properties are:

- the complete communication capabilities (CAN, LAN, USB and RS- 232)
- memory management
- ability to update the firmware of the 'resident system'

In addition the main system comprises the instrument functions that are divided into common functions like

- run synchronization through APG/ERI remote,
- error handling,
- diagnostic functions,
- or module specific functions like
 - internal events such as lamp control, filter movements,
 - raw data collection and conversion to absorbance.

Firmware Updates

Firmware updates can be done with the Agilent Lab Advisor software with files on the hard disk (latest version should be used).

Required tools, firmware and documentation are available from the Agilent web: <http://www.agilent.com/en-us/firmwareDownload?whid=69761>

The file naming conventions are:

PPPP_RVVV_XXX.dlb, where

- PPPP is the product number, for example, 1315B for the G1315B DAD,
- R the firmware revision, for example, A for G1315B or B for the G1315C DAD,
- VVV is the revision number, for example 650 is revision 6.50,
- XXX is the build number of the firmware.

For instructions on firmware updates refer to section *Replacing Firmware* in chapter "Maintenance" or use the documentation provided with the *Firmware Update Tools*.

NOTE

Update of main system can be done in the resident system only. Update of the resident system can be done in the main system only.

Main and resident firmware must be from the same set.

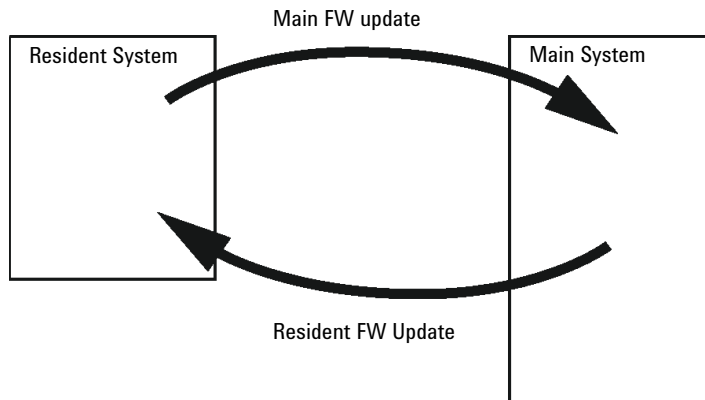

Figure 51 Firmware Update Mechanism

NOTE

Some modules are limited in downgrading due to their mainboard version or their initial firmware revision. For example, a G1315C DAD SL cannot be downgraded below firmware revision B.01.02 or to a A.xx.xx.

Some modules can be re-branded (e.g. G1314C to G1314B) to allow operation in specific control software environments. In this case, the feature set of the target type is used and the feature set of the original one is lost. After re-branding (e.g. from G1314B to G1314C), the original feature set is available again.

All this specific information is described in the documentation provided with the firmware update tools.

The firmware update tools, firmware and documentation are available from the Agilent web.

- <http://www.agilent.com/en-us/firmwareDownload?whid=69761>

Electrical Connections

- The CAN bus is a serial bus with high-speed data transfer. The two connectors for the CAN bus are used for internal module data transfer and synchronization.
- One analog output provides signals for integrators or data handling systems.
- The ERI/REMOTE connector may be used in combination with other analytical instruments from Agilent Technologies if you want to use features such as start, stop, common shutdown, prepare, and so on.
- With the appropriate software, the LAN connector may be used to control the module from a computer through a LAN connection. This connector is activated and can be configured with the configuration switch.
- With the appropriate software, the USB connector may be used to control the module from a computer through a USB connection.
- The power input socket accepts a line voltage of 100 – 240 VAC \pm 10 % with a line frequency of 50 or 60 Hz. Maximum power consumption varies by module. There is no voltage selector on your module because the power supply has wide-ranging capability. There are no externally accessible fuses because automatic electronic fuses are implemented in the power supply.

NOTE

Never use cables other than the ones supplied by Agilent Technologies to ensure proper functionality and compliance with safety or EMC regulations.

Rear View of the Module

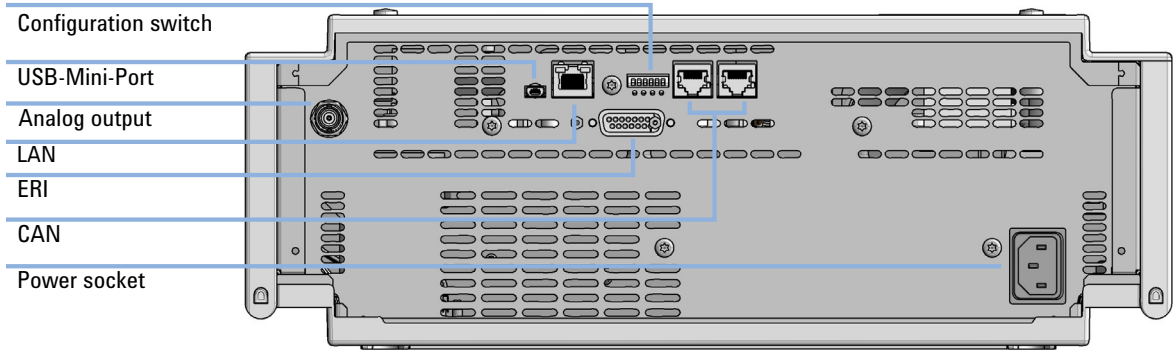

Figure 52 Rear view of detector (example shows a G7114A/B VWD) – electrical connections and label

Information on Instrument Serial Number

Serial Number Information 1200 Series and 1290 Infinity

The serial number information on the instrument labels provide the following information:

CCYWWSSSSS	Format
CC	country of manufacturing <ul style="list-style-type: none"> • DE = Germany • JP = Japan • CN = China
YWW	year and week of last major manufacturing change, e.g. 820 could be week 20 of 1998 or 2008
SSSSS	real serial number

Serial Number Information 1260/1290 Infinity

The serial number information on the instrument labels provide the following information:

CCXZZ00000	Format
CC	Country of manufacturing <ul style="list-style-type: none">• DE = Germany• JP = Japan• CN = China
X	Alphabetic character A-Z (used by manufacturing)
ZZ	Alpha-numeric code 0-9, A-Z, where each combination unambiguously denotes a module (there can be more than one code for the same module)
00000	Serial number

Interfaces

The Agilent InfinityLab LC Series modules provide the following interfaces:

Table 22 Agilent InfinityLab LC Series Interfaces

Module	CAN	USB	LAN (on-board)	RS-232	Analog	APG (A) / ERI (E)	Special
Pumps							
G7104A/C	2	No	Yes	Yes	1	A	
G7110B	2	Yes	Yes	No	No	E	
G7111A/B, G5654A	2	Yes	Yes	No	No	E	
G7112B	2	Yes	Yes	No	No	E	
G7120A, G7132A	2	No	Yes	Yes	1	A	
G7161A/B	2	Yes	Yes	No	No	E	
Samplers							
G7129A/B/C	2	Yes	Yes	No	No	E	
G7167A/B, G7137A, G5668A	2	Yes	Yes	No	No	E	
G7157A	2	Yes	Yes	No	No	E	
Detectors							
G7114A/B	2	Yes	Yes	No	1	E	
G7115A	2	Yes	Yes	No	1	E	
G7117A/B/C	2	Yes	Yes	No	1	E	
G7121A/B	2	Yes	Yes	No	1	E	
G7162A/B	2	Yes	Yes	No	1	E	
G7165A	2	Yes	Yes	No	1	E	

Table 22 Agilent InfinityLab LC Series Interfaces

Module	CAN	USB	LAN (on-board)	RS-232	Analog	APG (A) / ERI (E)	Special
Fraction Collectors							
G7158B	2	Yes	Yes	No	No	E	
G7159B	2	Yes	Yes	No	No	E	
G7166A	2	No	No	No	No	No	Requires a host module with on-board LAN with minimum FW B.06.40 or C.06.40, or with additional G1369C LAN Card
G1364E/F, G5664B	2	Yes	Yes	No	No	E	THERMOSTAT for G1330B
Others							
G7116A/B	2	No	No	No	No	No	Requires a host module with on-board LAN or with additional G1369C LAN Card.
G7122A	No	No	No	Yes	No	A	
G7170B	2	No	No	No	No	No	Requires a host module with on-board LAN with minimum FW B.06.40 or C.06.40, or with additional G1369C LAN Card

NOTE

The detector (DAD/MWD/FLD/VWD/RID) is the preferred access point for control via LAN. The inter-module communication is done via CAN.

- CAN connectors as interface to other modules
- LAN connector as interface to the control software
- RS-232C as interface to a computer
- USB (Universal Series Bus) as interface to a computer
- REMOTE connector as interface to other Agilent products
- Analog output connector(s) for signal output

Overview Interfaces

CAN

The CAN is inter-module communication interface. It is a 2-wire serial bus system supporting high speed data communication and real-time requirement.

LAN

The modules have either an interface slot for a LAN card (e.g. Agilent G1369B/C LAN Interface) or they have an on-board LAN interface (e.g. detectors G1315C/D DAD and G1365C/D MWD). This interface allows the control of the module/system via a PC with the appropriate control software. Some modules have neither on-board LAN nor an interface slot for a LAN card (e.g. G1170A Valve Drive or G4227A Flexible Cube). These are hosted modules and require a Host module with firmware B.06.40 or later or with additional G1369C LAN Card.

NOTE

If an Agilent detector (DAD/MWD/FLD/VWD/RID) is in the system, the LAN should be connected to the DAD/MWD/FLD/VWD/RID (due to higher data load). If no Agilent detector is part of the system, the LAN interface should be installed in the pump or autosampler.

USB

The USB interface replaces the RS-232 Serial interface in new FUSION generation modules. For details on USB refer to “USB (Universal Serial Bus)” on page 198.

Analog Signal Output

The analog signal output can be distributed to a recording device. For details refer to the description of the module’s mainboard.

Remote (ERI)

The ERI (Enhanced Remote Interface) connector may be used in combination with other analytical instruments from Agilent Technologies if you want to use features as common shut down, prepare, and so on.

It allows easy connection between single instruments or systems to ensure coordinated analysis with simple coupling requirements.

The subminiature D connector is used. The module provides one remote connector which is inputs/outputs (wired- or technique).

To provide maximum safety within a distributed analysis system, one line is dedicated to **SHUT DOWN** the system's critical parts in case any module detects a serious problem. To detect whether all participating modules are switched on or properly powered, one line is defined to summarize the **POWER ON** state of all connected modules. Control of analysis is maintained by signal readiness **READY** for next analysis, followed by **START** of run and optional **STOP** of run triggered on the respective lines. In addition **PREPARE** and **START REQUEST** may be issued. The signal levels are defined as:

- standard TTL levels (0 V is logic true, + 5.0 V is false),
- fan-out is 10,
- input load is 2.2 kOhm against + 5.0 V, and
- output are open collector type, inputs/outputs (wired- or technique).

NOTE

All common TTL circuits operate with a 5 V power supply. A TTL signal is defined as "low" or L when between 0 V and 0.8 V and "high" or H when between 2.0 V and 5.0 V (with respect to the ground terminal).

Table 23 ERI signal distribution

Pin	Signal	Description
1	START REQUEST	(L) Request to start injection cycle (for example, by start key on any module). Receiver is the autosampler.
2	STOP	(L) Request to reach system ready state as soon as possible (for example, stop run, abort or finish and stop injection). Receiver is any module performing run-time controlled activities.
3	READY	(H) System is ready for next analysis. Receiver is any sequence controller.
4	POWER ON	(H) All modules connected to system are switched on. Receiver is any module relying on operation of others.
5		Not used
6	SHUT DOWN	(L) System has serious problem (for example, leak: stops pump). Receiver is any module capable to reduce safety risk.
7	START	(L) Request to start run / timetable. Receiver is any module performing run-time controlled activities.
8	PREPARE	(L) Request to prepare for analysis (for example, calibration, detector lamp on). Receiver is any module performing pre-analysis activities.

Special Interfaces

There is no special interface for this module.

ERI (Enhanced Remote Interface)

ERI replaces the AGP Remote Interface that is used in the HP 1090/1040/1050/1100 HPLC systems and Agilent 1100/1200/1200 Infinity HPLC modules. All new InfinityLab LC Series products using the FUSION core electronics use ERI. This interface is already used in the Agilent Universal Interface Box 2 (UIB2)

ERI Description

The ERI interface contains eight individual programmable input/output pins. In addition, it provides 24 V power and 5 V power and a serial data line to detect and recognize further add-ons that could be connected to this interface. This way the interface can support various additional devices like sensors, triggers (in and out) and small controllers, etc.

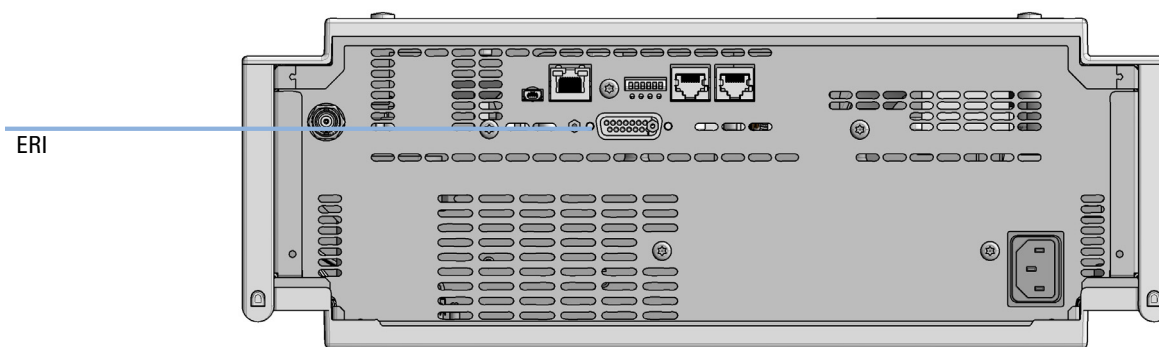

Figure 53 Location of the ERI interface (example shows a G7114A/B VWD)

	Pin	Enhanced Remote
<p>D-Sub female 15way user's view to connector</p> <p>IO1 IO2 IO3 IO4 IO5 IO6 IO7 IO8</p> <p>1 8 15 9</p> <p>1WEprom DGND +5V PGND PGND +24V +24V</p>	1	IO 1 (START REQUEST)
	2	IO 2 (STOP)
	3	IO 3 (READY)
	4	IO 4 (POWER ON)
	5	IO 5 (NOT USED)
	6	IO 6 (SHUT DOWN)
	7	IO 7 (START)
	8	IO 8 (PREPARE)
	9	1 wire DATA
	10	DGND
	11	+5 V ERI out
	12	PGND
	13	PGND
	14	+24 V ERI out
	15	+24 V ERI out

IO (Input/Output) Lines

- Eight generic bi-directional channels (input or output).
- Same as the APG Remote.
- Devices like valves, relays, ADCs, DACs, controllers can be supported/controlled.

1-Wire Data (Future Use)

This serial line can be used to read out an EPROM or write into an EPROM of a connected ERI-device. The firmware can detect the connected type of device automatically and update information in the device (if required).

5V Distribution (Future Use)

- Available directly after turning on the hosting module (assures that the firmware can detect certain basic functionality of the device).
- For digital circuits or similar.
- Provides 500 mA maximum.
- Short-circuit proof with automatic switch off (by firmware).

24V Distribution (Future Use)

- Available by firmware command (defined turn on/off).
- For devices that need higher power
 - Class 0: 0.5 A maximum (12 W)
 - Class 1: 1.0 A maximum (24 W)
 - Class 2: 2.0 A maximum (48 W)
- Class depends on hosting module's internal power overhead.
- If a connected device requires more power the firmware detects this (overcurrent detection) and provides the information to the user interface.
- Fuse used for safety protection (on board).
- Short circuit will be detected through hardware.

USB (Universal Serial Bus)

USB (Universal Serial Bus) - replaces RS232, supports:

- a PC with control software (for example Agilent Lab Advisor)
- USB Flash Disk

Setting the 6-bit Configuration Switch

The 6-bit configuration switch is located at the rear of the module with FUSION electronics. Switch settings provide configuration parameters for LAN and instrument specific initialization procedures.

All modules with FUSION electronics:

- Default is ALL switches DOWN (best settings).
 - Default IP address for LAN 192.168.254.11
- For specific LAN modes switches 4-5 must be set as required.
- For boot resident/cold start modes switches 1+2 or 6 must be UP.

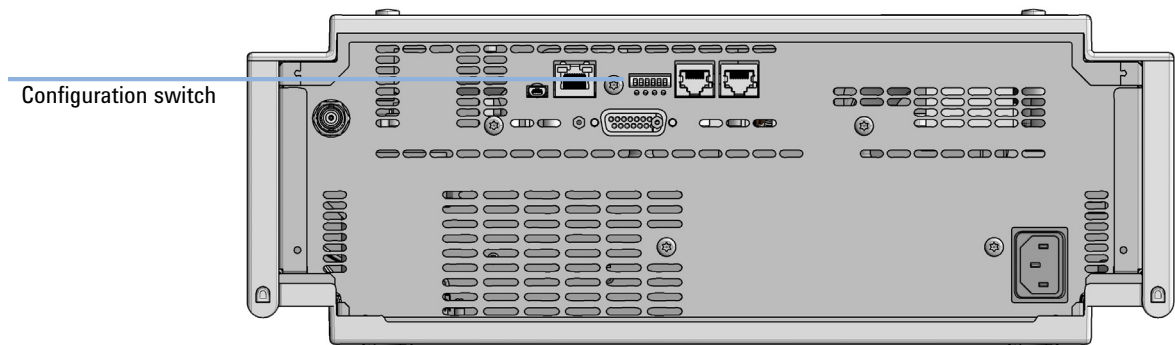

Figure 54 Location of Configuration switch (example shows a G7114A/B VWD)

Table 24 6-bit Configuration Switch

	Mode	Function/Setting				
	Switch 1	Switch 2	Switch 3	Switch 4	Switch 5	Switch 6
COM ¹	0	n.a. ²	n.a.	LAN Init Mode		n.a.
Use Default IP Address ³		0	0	0	0	0
Use Stored IP Address		0	0	0	1	0
Use DHCP to request IP Address ⁴		0	0	1	0	0
Test	1	System	n.a.	n.a.	n.a.	ColdStart
Boot Main System / Keep Data		0	0	0	0	0
Boot Resident System / Keep Data		1	0	0	0	0
Boot Main System / Revert to Default Data		0	0	0	0	1
Boot Resident System / Revert to Default Data		1	0	0	0	1

¹ When selecting mode COM, settings are stored to non-volatile memory. When selecting mode TEST, COM settings are taken from non-volatile memory.

² not assigned - Always keep these switches on position '0' (off)

³ Default IP Address is 192.168.254.11

⁴ Host Name will be the MAC address.

Special Settings

Boot-Resident/Main

Firmware update procedures may require this mode in case of firmware loading errors (main/resident firmware part).

If you use the following switch settings and power the instrument up again, the instrument firmware stays in the resident/main mode. In resident mode, it is not operable as a module. It only uses basic functions of the operating system for example, for communication. In this mode the main firmware can be loaded (using update utilities).

Forced Cold Start

A forced cold start can be used to bring the module into a defined mode with default parameter settings.

- **Boot Main System / Revert to Default Data**
The instrument will boot to main mode and changes to the module's default parameter. May be also required to load resident firmware into the module.
- **Boot Resident System / Revert to Default Data**
The instrument will boot to resident mode and changes to the module's default parameter. May be also required to load main firmware into the module.

CAUTION

Loss of data

Forced cold start erases all methods and data stored in the non-volatile memory. Exceptions are calibration settings, diagnosis and repair log books which will not be erased.

- ✓ **Save your methods and data before executing a forced cold start.**

If you use the following switch settings and power the instrument up again, it will start as described above.

Table 25 Boot Resident / Forced Coldstart

	SW1	SW2	SW3	SW4	SW5	SW6	Init Mode
	1	0	0	0	0	0	Boot Main System / Keep Data
	1	1	0	0	0	0	Boot Resident System / Keep Data
	1	0	0	0	0	1	Boot Main System / Revert to Default Data
	1	1	0	0	0	1	Boot Resident System / Revert to Default Data

Note: The setting '0' (down) is essential.

Instrument Layout

The industrial design of the module incorporates several innovative features. It uses Agilent's E-PAC concept for the packaging of electronics and mechanical assemblies. This concept is based upon the use of expanded polypropylene (EPP) layers of foam plastic spacers in which the mechanical and electronic boards components of the module are placed. This pack is then housed in a metal inner cabinet which is enclosed by a plastic external cabinet. The advantages of this packaging technology are:

- virtual elimination of fixing screws, bolts or ties, reducing the number of components and increasing the speed of assembly/disassembly,
- the plastic layers have air channels molded into them so that cooling air can be guided exactly to the required locations,
- the plastic layers help cushion the electronic and mechanical parts from physical shock, and
- the metal inner cabinet shields the internal electronics from electromagnetic interference and also helps to reduce or eliminate radio frequency emissions from the instrument itself.

Early Maintenance Feedback (EMF)

Maintenance requires the exchange of components which are subject to wear or stress. Ideally, the frequency at which components are exchanged should be based on the intensity of usage of the module and the analytical conditions, and not on a predefined time interval. The early maintenance feedback (**EMF**) feature monitors the usage of specific components in the instrument, and provides feedback when the user-selectable limits have been exceeded. The visual feedback in the user interface provides an indication that maintenance procedures should be scheduled.

EMF Counters

EMF counters increment with use and can be assigned a maximum limit which provides visual feedback in the user interface when the limit is exceeded. Some counters can be reset to zero after the required maintenance procedure.

Lamp Type	Counter Reset	Comment
lamp with RFID tag	NO	
lamp without RFID tag	YES	via Lab Advisor or Instant Pilot

The detector provides the following EMF counters:

- Deuterium Lamp On-Time
- Number of UV lamp ignitions

Using the **EMF Counters**

The user-settable **EMF** limits for the **EMF Counters** enable the early maintenance feedback to be adapted to specific user requirements. The useful maintenance cycle is dependent on the requirements for use. Therefore, the definition of the maximum limits need to be determined based on the specific operating conditions of the instrument.

Setting the EMF Limits

The setting of the **EMF** limits must be optimized over one or two maintenance cycles. Initially the default **EMF** limits should be set. When instrument performance indicates maintenance is necessary, take note of the values displayed by the **EMF counters**. Enter these values (or values slightly less than the displayed values) as **EMF** limits, and then reset the **EMF counters** to zero. The next time the **EMF counters** exceed the new **EMF** limits, the **EMF** flag will be displayed, providing a reminder that maintenance needs to be scheduled.

NOTE

This function is only available via Agilent Lab Advisor or Instant Pilot.

13

LAN Configuration

What You Have to Do First	207
TCP/IP parameter configuration	208
Configuration Switch	209
Initialization Mode Selection	210
Dynamic Host Configuration Protocol (DHCP)	212
General Information (DHCP)	212
Setup (DHCP)	213
Manual Configuration	215
With Telnet	216

This chapter provides information on connecting the module to the Agilent ChemStation PC.

What You Have to Do First

The module has an on-board LAN communication interface.

NOTE

This chapter is generic and may show figures that differ from your module. The functionality is the same.

- 1 Note the MAC (Media Access Control) address for further reference. The MAC or hardware address of the LAN interfaces is a world wide unique identifier. No other network device will have the same hardware address. The MAC address can be found on a label at the rear of the module underneath the configuration switch (see [Figure 56](#) on page 207).

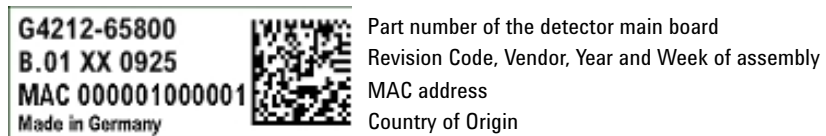

Figure 55 MAC-Label

- 2 Connect the instrument's LAN interface (see [Figure 56](#) on page 207) to
 - the PC network card using a crossover network cable (point-to-point) or
 - a hub or switch using a standard LAN cable.

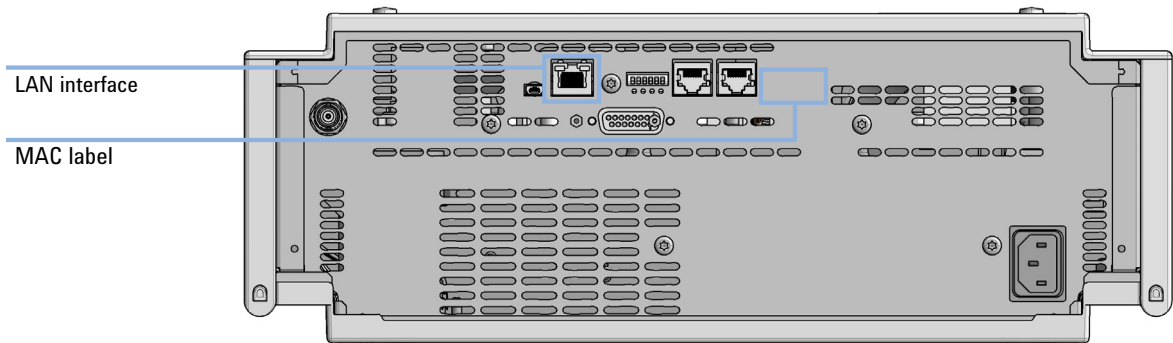

Figure 56 Location of LAN interfaces and MAC label

TCP/IP parameter configuration

To operate properly in a network environment, the LAN interface must be configured with valid TCP/IP network parameters. These parameters are:

- IP address
- Subnet Mask
- Default Gateway

The TCP/IP parameters can be configured by the following methods:

- by automatically requesting the parameters from a network-based DHCP Server (using the so-called Dynamic Host Configuration Protocol). This mode requires a LAN-onboard Module or a G1369C LAN Interface card, see “[Setup \(DHCP\)](#)” on page 213
- by manually setting the parameters using Telnet
- by manually setting the parameters using the Local Controller

The LAN interface differentiates between several initialization modes. The initialization mode (short form ‘init mode’) defines how to determine the active TCP/IP parameters after power-on. The parameters may be derived non-volatile memory or initialized with known default values. The initialization mode is selected by the configuration switch, see [Table 26](#) on page 210.

Configuration Switch

The configuration switch can be accessed at the rear of the module.

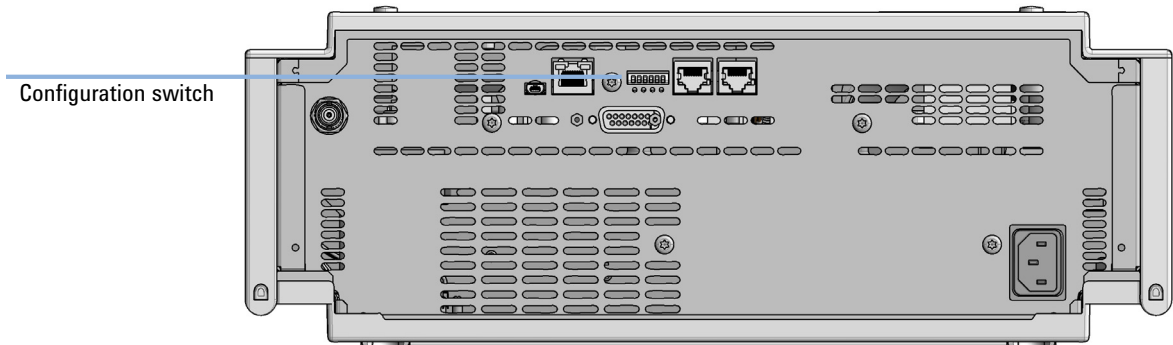

Figure 57 Location of Configuration switch (example shows a G7114A/B VWD)

The module is shipped with all switches set to OFF, as shown above.

NOTE

To perform any LAN configuration, SW1 and SW2 must be set to OFF.

Initialization Mode Selection

The following initialization (init) modes are selectable:

Table 26 Initialization Mode Switches

	SW1	SW2	SW3	SW4	SW5	SW6	Init Mode
	0	0	0	0	0	0	Use Default IP Address
	0	0	0	0	1	0	Use Stored IP Address
	0	0	0	1	0	0	Use DHCP

Note: The setting '0' (down) is essential.

Default IP address for LAN is 192.168.254.11.

DHCP address is the module's LAN MAC address.

Using Stored

When initialization mode **Using Stored** is selected, the parameters are taken from the non-volatile memory of the module. The TCP/IP connection will be established using these parameters. The parameters were configured previously by one of the described methods.

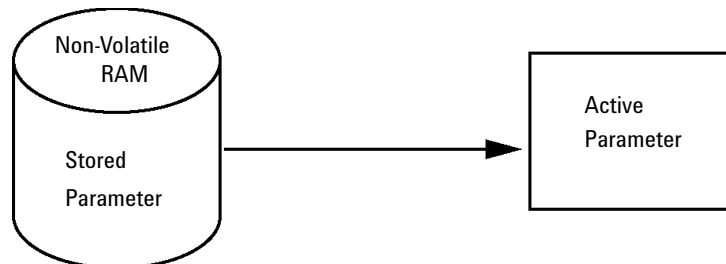

Figure 58 Using Stored (Principle)

Using Default

When **Using Default** is selected, the factory default parameters are taken instead. These parameters enable a TCP/IP connection to the LAN interface without further configuration, see [Table 27](#) on page 211.

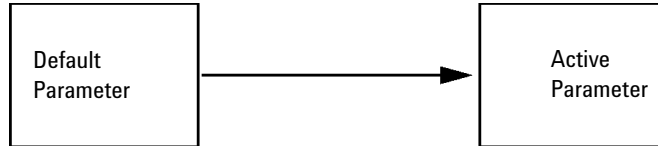

Figure 59 Using Default (Principle)

NOTE

Using the default address in your local area network may result in network problems. Take care and change it to a valid address immediately.

Table 27 Using Default Parameters

IP address:	192.168.254.11
Subnet Mask:	255.255.255.0
Default Gateway	not specified

Since the default IP address is a so-called local address, it will not be routed by any network device. Thus, the PC and the module must reside in the same subnet.

The user may open a Telnet session using the default IP address and change the parameters stored in the non-volatile memory of the module. He may then close the session, select the initialization mode Using Stored, power-on again and establish the TCP/IP connection using the new parameters.

When the module is wired to the PC directly (e.g. using a cross-over cable or a local hub), separated from the local area network, the user may simply keep the default parameters to establish the TCP/IP connection.

NOTE

In the **Using Default** mode, the parameters stored in the memory of the module are not cleared automatically. If not changed by the user, they are still available, when switching back to the mode Using Stored.

Dynamic Host Configuration Protocol (DHCP)

General Information (DHCP)

The Dynamic Host Configuration Protocol (DHCP) is an auto configuration protocol used on IP networks. The DHCP functionality is available on all Agilent HPLC modules with on-board LAN Interface or LAN Interface Card G1369C, and "B"-firmware (B.06.40 or above) or modules with "D"-firmware. All modules should use latest firmware from the same set.

When the initialization mode "DHCP" is selected, the card tries to download the parameters from a DHCP Server. The parameters obtained become the active parameters immediately. They are not stored to the non-volatile memory of the card.

Besides requesting the network parameters, the card also submits its hostname to the DHCP Server. The hostname equals the MAC address of the card, e.g. *0030d3177321*. It is the DHCP server's responsibility to forward the hostname/address information to the Domain Name Server. The card does not offer any services for hostname resolution (e.g. NetBIOS).

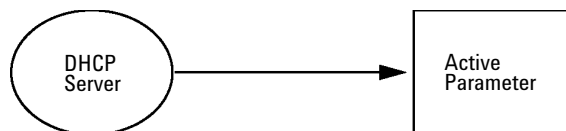

Figure 60 DHCP (Principle)

NOTE

- 1 It may take some time until the DHCP server has updated the DNS server with the hostname information.
- 2 It may be necessary to fully qualify the hostname with the DNS suffix, e.g. *0030d3177321.country.company.com*.
- 3 The DHCP server may reject the hostname proposed by the card and assign a name following local naming conventions.

Setup (DHCP)

The DHCP functionality is available on all Agilent HPLC modules with on-board LAN Interface or LAN Interface Card G1369C, and "B"-firmware (B.06.40 or above) or modules with "D"-firmware. All modules should use latest firmware from the same set.

- 1 Note the MAC address of the LAN interface (provided with G1369C LAN Interface Card or mainboard). This MAC address is on a label on the card or at the rear of the mainboard, for example, *0030d3177321*.

On the Local Controller the MAC address can be found under **Details** in the LAN section.

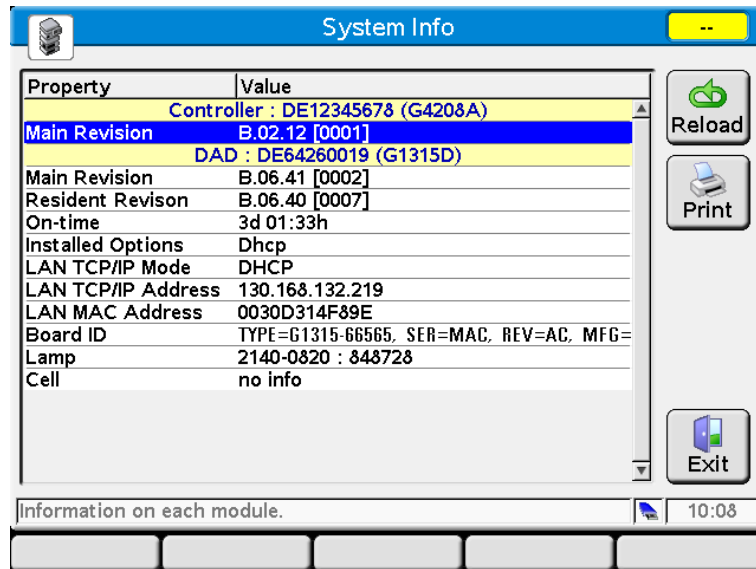

Figure 61 LAN Setting on Instant Pilot

LAN Configuration

Dynamic Host Configuration Protocol (DHCP)

- Set the configuration switch to DHCP either on the G1369C LAN Interface Card or the mainboard of above mentioned modules.

Table 28 G1369C LAN Interface Card (configuration switch on the card)

SW 4	SW 5	SW 6	SW 7	SW 8	Initialization Mode
ON	OFF	OFF	OFF	OFF	DHCP

Table 29 LC Modules with 8-bit configuration switch (B-firmware) (configuration switch at rear of the instrument)

SW 6	SW 7	SW 8	Initialization Mode
ON	OFF	OFF	DHCP

- Turn on the module that hosts the LAN interface.
- Configure your Control Software (e.g. OpenLAB CDS ChemStation Edition, Lab Advisor, Firmware Update Tool) and use MAC address as host name, e.g. *0030d3177321*.

The LC system should become visible in the control software (see Note in section “General Information (DHCP)” on page 212).

Manual Configuration

Manual configuration only alters the set of parameters stored in the non-volatile memory of the module. It never affects the currently active parameters. Therefore, manual configuration can be done at any time. A power cycle is mandatory to make the stored parameters become the active parameters, given that the initialization mode selection switches are allowing it.

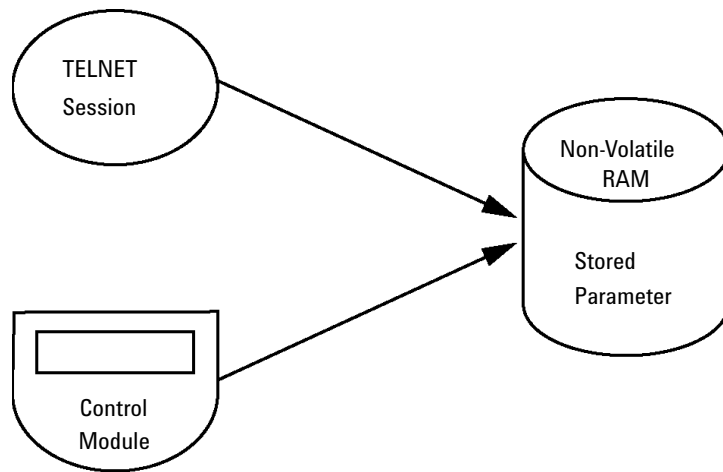
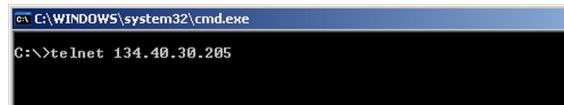

Figure 62 Manual Configuration (Principle)

With Telnet

Whenever a TCP/IP connection to the module is possible (TCP/IP parameters set by any method), the parameters may be altered by opening a Telnet session.

- 1 Open the system (DOS) prompt window by clicking on Windows **START** button and select **"Run..."**. Type "cmd" and press OK.
- 2 Type the following at the system (DOS) prompt:
 - c:\>telnet <IP address> or
 - c:\>telnet <host name>



```
C:\WINDOWS\system32\cmd.exe
C:\>telnet 134.40.30.205
```

Figure 63 Telnet - Starting a session

where <IP address> may be the assigned address from a Bootp cycle, a configuration session with the Handheld Controller, or the default IP address (see "Configuration Switch" on page 209).

When the connection was established successfully, the module responds with the following:

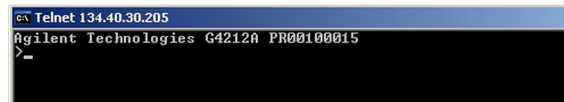

```
Telnet 134.40.30.205
Agilent Technologies G4212A PR00100015
>_
```

Figure 64 A connection to the module is made

- 3 Type `?` and press enter to see the available commands.

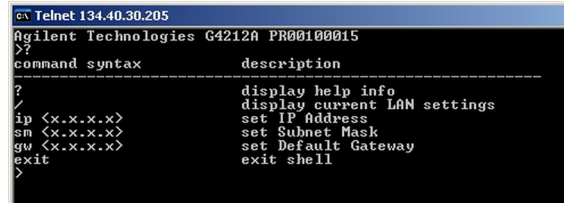

```

c:\ Telnet 134.40.30.205
Agilent Technologies G4212A PR00100015
>?
command syntax          description
-----
?                        display help info
/                        display current LAN settings
ip <x.x.x.x>             set IP Address
sm <x.x.x.x>             set Subnet Mask
gw <x.x.x.x>             set Default Gateway
exit                    exit shell
>

```

Figure 65 Telnet Commands

Table 30 Telnet Commands

Value	Description
<code>?</code>	displays syntax and descriptions of commands
<code>/</code>	displays current LAN settings
<code>ip <x.x.x.x></code>	sets new ip address
<code>sm <x.x.x.x></code>	sets new subnet mask
<code>gw <x.x.x.x></code>	sets new default gateway
<code>exit</code>	exits shell and saves all changes

- 4 To change a parameter follows the style:

- parameter value, for example:
`ip 134.40.28.56`

Then press [Enter], where parameter refers to the configuration parameter you are defining, and value refers to the definitions you are assigning to that parameter. Each parameter entry is followed by a carriage return.

- 5 Use the "/" and press Enter to list the current settings.

```

c:\ Telnet 134.40.30.205
>/
LAN Status Page
-----
MAC Address   : 0030D317521C
Init Mode    : Using Stored
-----
TCP/IP Properties
- active -
IP Address   : 134.40.30.205
Subnet Mask  : 255.255.248.0
Def. Gateway : 134.40.24.1
-----
TCP/IP Status : Ready
Controllers  : no connections
>_

```

Figure 66 Telnet - Current settings in "Using Stored" mode

information about the LAN interface
MAC address, initialization mode
Initialization mode is Using Stored
active TCP/IP settings

TCP/IP status - here ready
connected to PC with controller software (e.g. Agilent
ChemStation), here not connected

- 6 Change the IP address (in this example 192.168.254.12) and type "/" to list current settings.

```

c:\ Telnet 134.40.30.205
>ip 192.168.254.12
>/
LAN Status Page
-----
MAC Address   : 0030D317521C
Init Mode    : Using Stored
-----
TCP/IP Properties
- active -
IP Address   : 134.40.30.205
Subnet Mask  : 255.255.248.0
Def. Gateway : 134.40.24.1
- stored -
IP Address   : 192.168.254.12
Subnet Mask  : 255.255.248.0
Def. Gateway : 134.40.24.1
-----
TCP/IP Status : Ready
Controllers  : no connections
>_

```

Figure 67 Telnet - Change IP settings

change of IP setting to
Initialization mode is Using Stored

active TCP/IP settings

stored TCP/IP settings in non-volatile memory

connected to PC with controller software (e.g. Agilent
ChemStation), here not connected

- 7 When you have finished typing the configuration parameters, type **exit** and press **Enter** to exit with storing parameters.

```

c:\ WINDOWS\system32\cmd.exe
Agilent Technologies G4212A PR00100015
>exit

Connection to host lost.
C:\>_

```

Figure 68 Closing the Telnet Session

NOTE

If the Initialization Mode Switch is changed now to "Using Stored" mode, the instrument will take the stored settings when the module is re-booted. In the example above it would be 192.168.254.12.

General Safety Information	220
General Safety Information	220
Safety Standards	220
General	220
Before Applying Power	221
Ground the Instrument	221
Do Not Operate in an Explosive Atmosphere	222
Do Not Remove the Instrument Cover	222
Do Not Modify the Instrument	222
In Case of Damage	222
Solvents	223
Safety Symbols	224
Refrigerant	226
Waste Electrical and Electronic Equipment (WEEE) Directive	229
Radio Interference	230
Sound Emission	231
Solvent Information	232
Declaration of Conformity for HOX2 Filter	233
Agilent Technologies on Internet	234

This chapter provides addition information on safety, legal and web.

General Safety Information

General Safety Information

The following general safety precautions must be observed during all phases of operation, service, and repair of this instrument. Failure to comply with these precautions or with specific warnings elsewhere in this manual violates safety standards of design, manufacture, and intended use of the instrument. Agilent Technologies assumes no liability for the customer's failure to comply with these requirements.

WARNING

Ensure the proper usage of the equipment.

The protection provided by the equipment may be impaired.

- ✓ **The operator of this instrument is advised to use the equipment in a manner as specified in this manual.**

Safety Standards

This is a Safety Class I instrument (provided with terminal for protective earthing) and has been manufactured and tested according to international safety standards.

General

Do not use this product in any manner not specified by the manufacturer. The protective features of this product may be impaired if it is used in a manner not specified in the operation instructions.

Before Applying Power

WARNING

Wrong voltage range, frequency or cabling
Personal injury or damage to the instrument

- ✓ Verify that the voltage range and frequency of your power distribution matches to the power specification of the individual instrument.
- ✓ Never use cables other than the ones supplied by Agilent Technologies to ensure proper functionality and compliance with safety or EMC regulations.
- ✓ Make all connections to the unit before applying power.

NOTE

Note the instrument's external markings described under "Safety Symbols" on page 224.

Ground the Instrument

WARNING

Missing electrical ground
Electrical shock

- ✓ If your product is provided with a grounding type power plug, the instrument chassis and cover must be connected to an electrical ground to minimize shock hazard.
- ✓ The ground pin must be firmly connected to an electrical ground (safety ground) terminal at the power outlet. Any interruption of the protective (grounding) conductor or disconnection of the protective earth terminal will cause a potential shock hazard that could result in personal injury.

Do Not Operate in an Explosive Atmosphere

WARNING

Presence of flammable gases or fumes

Explosion hazard

- ✓ Do not operate the instrument in the presence of flammable gases or fumes.
-

Do Not Remove the Instrument Cover

WARNING

Instrument covers removed

Electrical shock

- ✓ Do Not Remove the Instrument Cover
 - ✓ Only Agilent authorized personnel are allowed to remove instrument covers. Always disconnect the power cables and any external circuits before removing the instrument cover.
-

Do Not Modify the Instrument

Do not install substitute parts or perform any unauthorized modification to the product. Return the product to an Agilent Sales and Service Office for service and repair to ensure that safety features are maintained.

In Case of Damage

WARNING

Damage to the module

Personal injury (for example electrical shock, intoxication)

- ✓ Instruments that appear damaged or defective should be made inoperative and secured against unintended operation until they can be repaired by qualified service personnel.
-

Solvents

WARNING

Toxic, flammable and hazardous solvents, samples and reagents

The handling of solvents, samples and reagents can hold health and safety risks.

- ✓ When working with these substances observe appropriate safety procedures (for example by wearing goggles, safety gloves and protective clothing) as described in the material handling and safety data sheet supplied by the vendor, and follow good laboratory practice.
- ✓ Do not use solvents with an auto-ignition temperature below 200 °C (392 °F). Do not use solvents with a boiling point below 56 °C (133 °F).
- ✓ Avoid high vapor concentrations. Keep the solvent temperature at least 40 °C (72 °F) below the boiling point of the solvent used. This includes the solvent temperature in the sample compartment. For the solvents methanol and ethanol keep the solvent temperature at least 25 °C (45 °F) below the boiling point.
- ✓ Do not operate the instrument in an explosive atmosphere.
- ✓ Do not use solvents of ignition Class IIC according IEC 60079-20-1 (for example, carbon disulfide).
- ✓ Reduce the volume of substances to the minimum required for the analysis.
- ✓ Never exceed the maximum permissible volume of solvents (8 L) in the solvent cabinet. Do not use bottles that exceed the maximum permissible volume as specified in the usage guideline for solvent cabinet.
- ✓ Ground the waste container.
- ✓ Regularly check the filling level of the waste container. The residual free volume in the waste container must be large enough to collect the waste liquid.
- ✓ To achieve maximal safety, regularly check the tubing for correct installation.

NOTE

For details, see the usage guideline for the solvent cabinet. A printed copy of the guideline has been shipped with the solvent cabinet, electronic copies are available in the Agilent Information Center or via the Internet.

Safety Symbols

Table 31 Symbols













	The apparatus is marked with this symbol when the user shall refer to the instruction manual in order to protect risk of harm to the operator and to protect the apparatus against damage.
	Indicates dangerous voltages.
	Indicates a protected ground terminal.
	The apparatus is marked with this symbol when hot surfaces are available and the user should not touch it when heated up.
	Sample Cooler unit is designed as vapor-compression refrigeration system. Contains fluorinated greenhouse gas (refrigerant) according to the Kyoto protocol. For specifications of refrigerant, charge capacity, carbon dioxide equivalent (CDE), and global warming potential (GWP) see instrument label.
	Flammable Material For Sample Thermostat which uses flammable refrigerant consult Agilent Information Center / User Manual before attempting to install or service this equipment. All safety precautions must be followed.
	Confirms that a manufactured product complies with all applicable European Community directives. The European Declaration of Conformity is available at: http://regulations.corporate.agilent.com/DoC/search.htm
	Manufacturing date.
	Power symbol indicates On/Off. The apparatus is not completely disconnected from the mains supply when the power switch is in the Off position
	Pacemaker Magnets could affect the functioning of pacemakers and implanted heart defibrillators. A pacemaker could switch into test mode and cause illness. A heart defibrillator may stop working. If you wear these devices keep at least 55 mm distance to magnets. Warn others who wear these devices from getting too close to magnets.

Table 31 Symbols

	<p>Magnetic field</p> <p>Magnets produce a far-reaching, strong magnetic field. They could damage TVs and laptops, computer hard drives, credit and ATM cards, data storage media, mechanical watches, hearing aids and speakers. Keep magnets at least 25 mm away from devices and objects that could be damaged by strong magnetic fields.</p>
	Indicates a pinching or crushing hazard
	Indicates a piercing or cutting hazard.

WARNING

A WARNING

alerts you to situations that could cause physical injury or death.

- ✓ Do not proceed beyond a warning until you have fully understood and met the indicated conditions.

CAUTION

A CAUTION

alerts you to situations that could cause loss of data, or damage of equipment.

- ✓ Do not proceed beyond a caution until you have fully understood and met the indicated conditions.

Refrigerant

The refrigerant HFC-134a is used only in the Agilent Infinity II Sample Cooler.

Table 32 Physical properties of refrigerant HFC-134a

Molecular weight	102
Critical temperature	101.1 °C
Critical pressure	40.6 bar
Boiling point	-26.5 °C

Table 33 Physical properties of refrigerant R600a (isobutane)

Molecular weight	58.12
Critical temperature	134.98 °C
Critical pressure	36.6 bar
Boiling point	-11.7 °C

WARNING

Refrigerant



Refrigerant HFC-134a is known as a safe refrigerant, however accidents can occur if it is handled incorrectly. For this reason, the following instructions must be observed:

- ✓ Avoid contact with liquid refrigerant HFC-134a. At atmospheric pressure HFC-134a evaporates at approximately -26 °C and causes frost bite.
 - ✓ After skin contact, rinse the affected area with water.
 - ✓ After eye contact, rinse the eye(s) with plenty of water for at least 15 minutes and consult a doctor.
 - ✓ HFC-134a must not be allowed to escape in enclosed areas. Although HFC-134a is not toxic, there is a danger of suffocation as gaseous refrigerant is heavier than air.
 - ✓ Please observe the following first aid instructions. After inhalation, move the affected person to fresh air, keep him warm and allow him to rest. If necessary, he should be supplied with oxygen. If he has stopped breathing or is breathing erratically, he should be given artificial respiration. In the case of cardiac arrest, carry out heart massage. Send for a doctor immediately.
 - ✓ Moreover, it must be noted that HFC-134a must always be extracted from the system and collected. It must never be discharged into the atmosphere on environmental grounds (greenhouse effect).
-

CAUTION**General hazards and improper disposal**

Improper disposal of the media and components used pollutes the environment.

- ✓ The disposal or scrapping of the Sample Cooler or the Sample Thermostat must be carried out by a qualified disposal company.
 - ✓ All media must be disposed of in accordance with national and local regulations.
 - ✓ Please contact your local Agilent Service Center in regard to safe environmental disposal of the appliance or check www.agilent.com for more info.
-

CAUTION**Risk of fire or explosion**

- ✓ Dispose of properly in accordance with federal or local regulations. Flammable Refrigerant Used.
 - ✓ Do not dispose of in domestic household waste.
 - ✓ To return unwanted products, contact your local Agilent office, or see <http://www.agilent.com> for more information.
-

Waste Electrical and Electronic Equipment (WEEE) Directive

This product complies with the European WEEE Directive marking requirements. The affixed label indicates that you must not discard this electrical/electronic product in domestic household waste.



NOTE

Do not dispose of in domestic household waste

To return unwanted products, contact your local Agilent office, or see <http://www.agilent.com> for more information.

Radio Interference

Cables supplied by Agilent Technologies are screened to provide optimized protection against radio interference. All cables are in compliance with safety or EMC regulations.

Test and Measurement

If test and measurement equipment is operated with unscreened cables, or used for measurements on open set-ups, the user has to assure that under operating conditions the radio interference limits are still met within the premises.

Sound Emission

Sound pressure

Sound pressure $L_p < 70$ db(A) according to DIN-EN 27779

Schalldruckpegel

Schalldruckpegel $L_p < 70$ db(A) nach DIN-EN 27779

Solvent Information

Flow Cell

To protect optimal functionality of your flow-cell:

- Avoid the use of alkaline solutions (pH > 9.5) which can attack quartz and thus impair the optical properties of the flow cell.

Use of Solvents

Observe the following recommendations on the use of solvents.



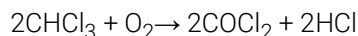

- Brown glass ware can avoid growth of algae.
- Avoid the use of the following steel-corrosive solvents:
 - solutions of alkali halides and their respective acids (for example, lithium iodide, potassium chloride, and so on),
 - high concentrations of inorganic acids like sulfuric acid and nitric acid, especially at higher temperatures (if your chromatography method allows, replace by phosphoric acid or phosphate buffer which are less corrosive against stainless steel),
 - halogenated solvents or mixtures which form radicals and/or acids, for example:

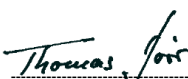

This reaction, in which stainless steel probably acts as a catalyst, occurs quickly with dried chloroform if the drying process removes the stabilizing alcohol,

- chromatographic grade ethers, which can contain peroxides (for example, THF, dioxane, diisopropyl ether) should be filtered through dry aluminium oxide which adsorbs the peroxides,
 - solvents containing strong complexing agents (e.g. EDTA),
 - mixtures of carbon tetrachloride with 2-propanol or THF.
- Avoid the use of dimethyl formamide (DMF). Polyvinylidene fluoride (PVDF), which is used in leak sensors, is not resistant to DMF.

Declaration of Conformity for HOX2 Filter

Declaration of Conformity																											
<p>We herewith inform you that the</p> <p style="text-align: center;">Holmium Oxide Glass Filter</p> <p>used in Agilent's absorbance detectors listed in the table below meets the requirements of National Institute of Standards and Technology (NIST) to be applied as certified wavelength standard.</p> <p>According to the publication of NIST in J. Res. Natl. Inst. Stand. Technol. 112, 303-306 (2007) the holmium oxide glass filters are inherently stable with respect to the wavelength scale and need no recertification. The expanded uncertainty of the certified wavelength values is 0.2 nm.</p> <p>Agilent Technologies guarantees, as required by NIST, that the material of the filters is holmium oxide glass representing the inherently existent holmium oxide absorption bands.</p> <p>Test wavelengths:</p> <p>Where "x" can be any alphanumeric character</p> <table border="1" style="width: 100%; border-collapse: collapse; margin-top: 10px;"> <thead> <tr> <th style="width: 25%;">Product Number</th> <th style="width: 25%;">Series</th> <th style="width: 25%;">Measured Wavelength *</th> <th style="width: 15%;">Wavelength Accuracy</th> <th style="width: 10%;">Optical Bandwidth</th> </tr> </thead> <tbody> <tr> <td>G1315x, G1365x</td> <td>1100, 1200, 1260</td> <td rowspan="3">361.0 nm 418.9 nm 453.7 nm 536.7 nm</td> <td rowspan="3">+/- 1 nm</td> <td rowspan="3">2 nm</td> </tr> <tr> <td>G7115x, G7165x</td> <td>1260</td> </tr> <tr> <td>G1600x, G7100x</td> <td>CE</td> </tr> <tr> <td>G1314x</td> <td>1100, 1200, 1260, 1290</td> <td rowspan="3">360.8nm 418.5nm 536.4nm</td> <td rowspan="3">+/- 1 nm</td> <td rowspan="3">6 nm</td> </tr> <tr> <td>G7114x</td> <td>1260, 1290</td> </tr> <tr> <td>G4286x,...., 94x</td> <td>1120, 1220</td> </tr> </tbody> </table> <p>*) The variation in Measured Wavelength depends on the different Optical Bandwidth.</p> <div style="text-align: center; margin-top: 20px;"> <p>28-Oct-2014</p> <p>-----</p> <p>(Date)</p> <div style="display: flex; justify-content: space-around; margin-top: 20px;"> <div style="text-align: center;">  ----- (R&D Manager) </div> <div style="text-align: center;">  ----- (Quality Manager) </div> </div> </div>					Product Number	Series	Measured Wavelength *	Wavelength Accuracy	Optical Bandwidth	G1315x, G1365x	1100, 1200, 1260	361.0 nm 418.9 nm 453.7 nm 536.7 nm	+/- 1 nm	2 nm	G7115x, G7165x	1260	G1600x, G7100x	CE	G1314x	1100, 1200, 1260, 1290	360.8nm 418.5nm 536.4nm	+/- 1 nm	6 nm	G7114x	1260, 1290	G4286x,...., 94x	1120, 1220
Product Number	Series	Measured Wavelength *	Wavelength Accuracy	Optical Bandwidth																							
G1315x, G1365x	1100, 1200, 1260	361.0 nm 418.9 nm 453.7 nm 536.7 nm	+/- 1 nm	2 nm																							
G7115x, G7165x	1260																										
G1600x, G7100x	CE																										
G1314x	1100, 1200, 1260, 1290	360.8nm 418.5nm 536.4nm	+/- 1 nm	6 nm																							
G7114x	1260, 1290																										
G4286x,...., 94x	1120, 1220																										
P/N 89550-90501 	Revision: G Effective by: 28-Oct-2014																										

Agilent Technologies on Internet

For the latest information on products and services visit our worldwide web site on the Internet at:

<http://www.agilent.com>

In This Book

This manual contains technical reference information about the Agilent 1290 Infinity II Variable Wavelength Detector (G7114B) and the Agilent 1260 Infinity II Variable Wavelength Detector (G7114A).

The manual describes the following:

- introduction and specifications,
- using and optimizing,
- troubleshooting and diagnose,
- maintenance,
- parts identification,
- hardware information,
- safety and related information.

www.agilent.com

© Agilent Technologies Inc. 2014-2020

Published in Germany
09/2020

Document No: SD-29000240 Rev. D

